



# CODE OF PRACTICE

For Design, Installation and Seismic Restraint  
of Suspended Ceilings

OCTOBER 2015



The purpose of this Code of Practice is to assist the construction industry, building consent authorities, architects, engineers, builders, installers and specifiers to comply with the New Zealand Building Code.

## **ASSOCIATION OF WALL AND CEILING INDUSTRIES OF NEW ZEALAND INC.**

The Association of Wall and Ceiling Industries of New Zealand Inc. is a grouping of building industry organisations, including contractors, tradespeople, manufacturers and suppliers, established to represent the interests of members and their customers for interior wall and ceiling lining systems and related products.

The Association was formed in 1992 as the Interior Systems Association incorporating existing trade groups of suspended ceilings, plasterboard and fibrous plaster. The name of the association was changed in November 2005.

AWCINZ membership is open to any interested party.

For further information, please contact [admin@awcinz.org.nz](mailto:admin@awcinz.org.nz) or go to [www.awcinz.org.nz](http://www.awcinz.org.nz).

## **ACKNOWLEDGEMENT**

This Code of Practice was prepared by a project team comprising:

Ruth Berry – BRANZ  
Keith Hogg – Hush Interiors Limited  
John Keen – USG Boral  
John Parkin – AWCI NZ  
Dennis Prout – Forman/Rondo

## **DOCUMENT HISTORY**

This document may be updated from time to time. Refer to the website [www.awcinz.org.nz](http://www.awcinz.org.nz) for the most recent updates of this Code of Practice:

<b>Version</b>	<b>Date</b>	<b>Amendments</b>
1st published edition	October 2015	

Comments on this Code of Practice are welcome, please send all comments to [admin@awcinz.org.nz](mailto:admin@awcinz.org.nz).

The production of this Code of Practice was funded by BRANZ whose support is gratefully acknowledged. Responsibility for the content lies solely with the Association of Wall and Ceiling Industries of New Zealand and does not necessarily reflect the opinion of BRANZ.





# Foreword

## **FOREWORD FROM THE MINISTRY OF BUSINESS INNOVATION AND EMPLOYMENT**

Damage to suspended ceilings from recent earthquakes has highlighted the need for correct design and installation of ceilings and other non-structural parts of buildings, such as partitions and building services. The failure of non-structural elements in an earthquake can injure or kill people and can prevent the uninterrupted use of buildings after an earthquake.

This new Code of Practice focuses on seismic restraints and separations for suspended ceilings and on the roles and responsibilities of those involved to ensure that suspended ceilings are designed and installed correctly. The co-ordination with designers and contractors working on other non-structural elements is also highlighted.

The Ministry congratulates the Association of Wall and Ceiling Industries on its initiative in producing this Code of Practice. It is encouraging to see industry groups creating their own guidance and codes of practice to complement Ministry guidance and Acceptable Solutions and Verification Methods. Note, however, that this Code of Practice is not part of the Ministry's Acceptable Solutions, Verification Methods or guidance documents.

Improving the compliance and performance of suspended ceilings will rely on greater awareness of responsibilities for design and installation from those involved in the construction industry. To this end, we hope that this Code of Practice will assist the industry with the procurement, design and installation of suspended ceilings.

# Contents

<b>1 Introduction</b>	<b>6</b>		
Possible reasons for failure of suspended ceilings	6	Plasterboard or other sheet-lined suspension systems	24
<b>2 Background</b>	<b>8</b>	Specialty or feature ceilings	25
Past industry practice	8	Linear and metal	26
The challenge for the industry	8	Curved ceilings	27
<b>3 AWCI seismic grade</b>	<b>10</b>	Floating cloud	28
Identifying the AWCI seismic grade of a ceiling	10	Ceilings below other ceilings	28
Cost considerations	11	Wind loads	29
<b>4 Design</b>	<b>12</b>	<b>Bulkheads</b>	<b>30</b>
The design process	12	<b>Ceiling components</b>	<b>33</b>
Roles and responsibilities of the parties involved in the design	12	Wall trims and perimeter channels	33
Design co-ordination	14	Fixing clips	34
Other trades in the plenum	14	Main tees	35
Seismic restraint of non-structural building components other than ceilings	14	Cross tees	36
Who does the design for other building components?	14	<b>7 Testing of product</b>	<b>37</b>
Co-ordination of design	14	<b>8 Manufacturers' generic seismic design guides</b>	<b>38</b>
<b>5 Design documentation</b>	<b>16</b>	<b>9 Specific engineering design (SED)</b>	<b>39</b>
Compliance with NZBC and standards	16	<b>10 Generic details</b>	<b>40</b>
Seismic design	16	Seismic separation joint details	40
Perimeter fixing	17	Lateral force bracing	43
Seismic forces	17	Perimeter restraint	44
Braced ceilings	17	Fixed-end options	45
Classification of parts (P2–P7)	18	Non-fixed-end options	48
Building importance level	18	<b>Tile clips</b>	<b>49</b>
<b>6 Ceiling types and components</b>	<b>21</b>	<b>Hangers</b>	<b>49</b>
Ceiling fixing methods	21	<b>Bridging</b>	<b>50</b>
Ceiling systems	21	Trapeze	51
Two-way exposed	21	<b>11 Possible reasons for and consequences of failure</b>	<b>52</b>
One-way exposed	22	<b>12 Tendering</b>	<b>54</b>
Fully concealed	23	Options for tendering	54
		Option 1: Where tender documents include full details of seismic restraints	54

Model tender qualification where seismic restraints are fully detailed	54	Design review producer statement (PS2)	65
<b>Option 2: Where seismic restraint design is required to be carried out at construction stage</b>	<b>55</b>	Construction producer statement (PS3)	66
Model tender qualification where seismic restraints are not detailed in tender documents	55	Construction review producer statement (PS4)	66
<b>Option 3: Specific engineering design</b>	<b>55</b>	<b>Construction monitoring (CM) levels</b>	<b>66</b>
Model tender qualification where specific engineering design is required	56	Level CM2	66
General tender qualifications	56	Level CM3	66
Tender, consent and shop drawings	56	Level CM4	66
<b>13 Installation</b>	<b>57</b>	<b>18 Summary of roles and responsibilities</b>	<b>67</b>
Site inspection	57	Designer	67
Material storage and handling	57	Ceiling tenderer	67
Pre-installation checklist	57	Installer	67
Facilities for installation of suspended ceilings	57	Building consent authority	68
Best-practice co-ordination with other ceiling services	58	<b>Appendices</b>	<b>69</b>
Installation details to seismic design	58	A. Definitions, abbreviations and notations	69
Aesthetics	58	B. Relevant standards and associated documents	73
Specialty tools	58	C. Tendering options guidelines	74
Quality assurance	58	D. Installer's producer statement (PS3) template	77
Inspection	59	E. Sample QA sheet	78
Refurbishment work	59	F. Design information list	79
<b>14 Partitions</b>	<b>60</b>		
<b>15 Fire and suspended ceilings</b>	<b>62</b>		
Passive fire	62		
<b>16 Acoustics</b>	<b>63</b>		
Sound absorption (NRC)	63		
Sound transmission (STC, CAC)	63		
<b>17 Monitoring design and construction</b>	<b>65</b>		
Producer statements	65		
Design producer statement (PS1)	65		

# Figures and tables

Table 1:	AWCI seismic grades for suspended ceilings	11	Figure 23:	Bulkhead off solid underfloor with two ceilings at different heights	30
Figure 1:	Change in relative cost of seismic requirements as complexity increases	11	Figure 24:	Suspended ceiling and bulkhead, cantilevered top ceiling support	31
Figure 2:	Recommended project process	13	Figure 25:	Suspended ceiling and bulkhead	31
Table 2:	Main steps and parties that may be involved	15	Figure 26:	Suspended ceiling and light trough bulkhead	32
Table 3:	Definitions	15	Figure 27:	Suspended ceiling to blind box detail	32
Figure 3:	Seismic layout concepts	17	Figure 28:	L trims, various sizes, equal and unequal leg length	33
Table 4:	Classification of building parts	18	Figure 29:	Shadow trims, various sizes	33
Table 5:	Building importance levels	19	Figure 30:	C channels, various sizes	33
Figure 4:	Exposed grid and tile system in place	21	Figure 31:	Wall shims, used at edges of ceilings to accommodate sloped ceilings	33
Figure 5:	Schematic diagram of two-way grid	21	Figure 32:	Perimeter clips	34
Figure 6:	Concealed edge	22	Figure 33:	Main beam joint clip	34
Figure 7:	Tee grid visible in only one direction	22	Figure 34:	Cross tee joint clip	34
Figure 8:	Schematic diagram of one-way exposed grid	22	Figure 35:	Three-way cross joint clip for off-module connection	34
Figure 9:	Back-to-back L splines	23	Figure 36:	Main tee, 24 mm face	35
Figure 10:	C and Z splines	23	Figure 37:	Fire-rated main tee, 24 mm face	35
Figure 11:	Tee grid	23	Figure 38:	Main tee, 15 mm face	35
Figure 12:	Concealed grid	23	Figure 39:	Cross tee, 24 mm face	36
Figure 13:	Suspended sheeted or flush ceiling grid system	24	Figure 40:	Cross tee, 15 mm face	36
Figure 14:	Direct fix sheeted or flush ceiling system	24	Figure 41:	Seismic separation joints shown in both directions	40
Figure 15:	Finished feature ceilings	25	Figure 42:	Small seismic joint, two directions, hidden joint	41
Figure 16:	Suspended linear or strip ceiling system	26	Figure 43:	Small seismic joint, one direction, hidden joint	41
Figure 17:	Curved ceiling schematic	27	Figure 44:	Seismic joint clip – main beam	41
Figure 18:	Proprietary linear ceiling system	27	Figure 45:	Seismic joint clip – cross tee	41
Figure 19:	Floating cloud ceilings	28	Figure 46:	Large seismic joint with concave cover strip	42
Figure 20:	Feature ceiling below another ceiling	28	Figure 47:	Large seismic joint with cover strip at bottom of T-rail	42
Figure 21:	Wind loads	29	Figure 48:	Large seismic joint with cover strip above T-rail	42
Figure 22:	Bulkhead off solid underfloor	30			

Figure 49: Lateral force bracing using solid struts	43	Figure 72: Generic internal wall bracing connection – wall terminates at ceiling	60
Figure 50: Lateral force bracing using splayed wires	43	Figure 73: Generic internal wall bracing connection – wall terminates above ceiling	61
Figure 51: Generic wall clip	44	Figure 74: Horizontal bracing	61
Figure 52: Proprietary perimeter restraint components, component in place with rails	44	Figure 75: Sound reflection	63
Figure 53: Pop rivet	45	Figure 76: Sound transmission	64
Figure 54: Pop rivet with spacer block (used with rebated tiles)	45	Table 6: Producer statements likely to be required according to seismic grade	65
Figure 55: Seismic clip – main or cross tee	46		
Figure 56: Seismic clip – cross tee with spacer block	46		
Figure 57: Seismic clip – main or cross tee with spacer block and shadow wall angle	47		
Figure 58: Seismic clip – wall angle and wall angle with spacer block	48		
Figure 59: Seismic channel	48		
Figure 60: Hanger wire minimum tie-off	49		
Figure 61: Bridging under ducts or services by other trades	50		
Figure 62: Typical trapeze	51		
Figure 63: Trapeze wire detail	51		
Figure 64: Lack of suspension points and service clearance	52		
Figure 65: Unbraced partitions and service ducts	52		
Figure 66: Sprinkler system supported from ceiling componentry rather than suspended as it should be	52		
Figure 67: The result of an unbraced ceiling	53		
Figure 68: Damage to ceiling tile from an unrestrained fire protection system	53		
Figure 69: Damage caused by unrestrained services	53		
Figure 70: Lack of suspension points	53		
Figure 71: Proprietary internal wall bracing connection (isolated from ceiling movement)	60		

# 1

## Introduction

Despite the requirements of various New Zealand standards,<sup>1</sup> the seismic compliance of ceilings has received scant attention in recent years. A series of major earthquakes in Christchurch in 2010 and 2011 and in Seddon in 2013, which also affected Wellington, highlighted a systemic problem.

Many ceilings, partitions and building services within ceiling voids collapsed, causing damage in commercial and institutional buildings. In some cases, poorly restrained ceilings failed along with the building services they were supporting, and in others, ceilings were compromised by unrestrained or poorly restrained building services and partitions. Overseas, there are examples in Japan and California where injury and loss of life have occurred as a result of ceilings and/or building services they were supporting failing.

According to a University of Canterbury report,<sup>2</sup> well over half of the costs incurred in the Christchurch earthquakes were associated with non-structural elements such as ceilings, partitions and services. The Insurance Council of New Zealand reported to a Parliamentary Select Committee in May 2014 that the cost of non-structural element failures had resulted in many otherwise repairable buildings being demolished.<sup>3</sup>

Aside from the obvious concerns about the safety of building occupants and widespread non-compliance with the New Zealand Building Code (NZBC), these avoidable losses are a significant burden on the New Zealand economy. The industry is under increasing pressure to assure seismic compliance on current and future construction projects.

### POSSIBLE REASONS FOR FAILURE OF SUSPENDED CEILINGS

There are many reasons for possible failure of the suspended ceiling, including but not limited to:

- the seismic performance of the building
- unsuitable ceiling design for the particular structure
- the use of an unsuitable product/system
- installation not meeting the requirements of either the manufacturer, supplier or the NZBC
- ceiling hangers not installed correctly
- services within the ceiling space or connected to the ceiling grid not installed to current codes
- perimeter walls or bulkheads insufficient to receive the live loads of a ceiling
- insufficient seismic gaps to allow for movement of the building structure
- partitions being connected to the ceiling system but not independently braced
- a lighter gauge of ceiling grid or non-tested system being installed outside its non-structural capability
- interference from other non-structural building components in the plenum.



This Code of Practice covers suspended ceilings only and highlights the need for effective co-ordination of the ceiling support and restraint systems with seismic restraints for the specialist building services installations whose requirements are governed by separate standards.

AWCINZ expects that the adoption of this Code of Practice – and the transition to fully compliant ceilings – will improve safety and reduce economic losses due to the failure of non-structural components.

- 1 Including NZS 1170.5:2004 *Structural design actions – Part 5: Earthquake actions – New Zealand*, AS/NZS 2785:2000 *Suspended ceilings – Design and installation*; NZS 4219:2009 *Seismic performance of engineering systems in buildings* and NZS 4541:2013 *Automatic fire sprinkler systems*.
- 2 Dhakal, R.P., MacRae, G.A. and Hogg, K. (2011). Performance of ceilings in the February 2011 Christchurch earthquake. *Bulletin of the New Zealand Society for Earthquake Engineering*, 44 (4): 379–389.
- 3 Submission to the Local Government and Environment Select Committee from the Insurance Council of New Zealand, 17 April 2014. <http://www.icnz.org.nz/wp-content/uploads/submission-buildings-earthquake-prone-buildings-amendment-bill-april2014.pdf>

## EARTHQUAKE DAMAGE TO CEILINGS AND SERVICES



Damage caused by unrestrained services.



Damage from unrestrained fire protection system.



The result of an unbraced ceiling.



Damage caused by unrestrained ducting.

# 2

## Background

### PAST INDUSTRY PRACTICE

In many cases, the design for seismic restraint of suspended ceilings has been an afterthought or not done at all. The scope of the seismic restraints and related engineering work required has also often not been known until the ceiling design has been completed. A typical approach has been as follows:

- Architects and engineers seldom provide all necessary technical information required to design the seismic restraints for a particular building at the time of tendering. Tenders are based on specifications and reflected ceiling plans. The suspended ceiling contractor works with the main contractor to agree aesthetic details such as edge trim, bulkheads, seismic breaks, trimming for light fittings and grilles and service tiles. Shop drawings are provided only where required to clarify details.
- Ceiling hangers are set out with hangers at the spacings required for the gravity support of the selected ceiling system. Often, they are cut or moved by other trades to allow building services to be installed, or services are installed without the clear spacing required under NZS 4219:2009.
- Product-specific seismic design and installation guides available from key industry manufacturers and suppliers offer a range of generic details, but they do not eliminate the need for the structural engineering design to achieve and demonstrate seismic compliance. A structural engineer may inspect the work to decide where seismic restraints and braces can be fitted to achieve the required level of seismic design detail.

In addition, a market driven by the lowest tender price provides little incentive to properly address seismic restraints at budget and tender stage. A suspended ceiling contractor who allows for a seismically compliant

ceiling is unlikely to win against lower-priced competitors who 'tag out' seismic restraints, allow a nominal provisional sum or overlook the matter completely.

A persistent failure to address the matter as an early-stage design issue has resulted in non-conforming ceilings, avoidable rework, financial losses and disputes. Rectification of issues associated with ceilings that have inadequate seismic restraint costs ceiling contractors in terms of additional work required due to lack of co-ordination of non-structural components, disputes and potential litigation should the ceiling subsequently fail.

### THE CHALLENGE FOR THE INDUSTRY

At the time of tender, a number of factors need to be known (for a comprehensive list, see Appendix F):

- Location of the building
- Building importance level
- Parts category (from NZS 1170.5:2004 section 8)
- Annual probability of exceedance (return period)
- AWCI seismic grade
- A set of relevant working drawings
- Height of the ceiling seismic attachment from ground level
- Seismic mass (including weights of linings, insulation and service load provisions)
- Wind load.

Regardless of past industry practice, it is not acceptable to treat seismic restraints and related structural engineering design, monitoring and certification as if they were optional. The industry must therefore revisit its practices in the procurement of buildings and in the methodology of all stages of design and construction to assure compliance with minimal added cost.

The industry needs to change the way it designs, procures, installs and certifies suspended ceilings and co-ordinates the seismic design details with other building elements.

The AWCINZ challenge to industry is to ensure that seismic design of suspended ceilings and building services is addressed in a co-ordinated manner, at the earliest possible stage of design, before tenders are called, which will reduce uncertainty, define the scope of work and allow tenderers to provide a firm price for the ceiling system. Leaving the seismic design details until later creates risk and uncertainty for all.

At time of tender, the information below may also be required:

- How the building structure has been designed to perform in an earthquake event.
- How the ceiling supports and restraints may be co-ordinated with the structure.
- The space that will be available in the ceiling void for seismic restraints.
- How ceiling supports and restraints will be co-ordinated with the building services to be installed in the ceiling void for which detailed shop drawings have not yet been produced.

- The cost of engaging a qualified structural engineer with specialist knowledge of suspended ceilings to design and certify the design of the seismic restraints for each area of ceiling.
- The type and extent of seismic restraints that will be required by the structural engineer and consequently their cost.
- The cost of engaging the specialist structural engineer to monitor installation work (including the number of inspections required by the main contractor's construction programme) and to certify the completed installation.

This challenge cannot be met by the suspended ceilings industry alone. As there is no 'standard' building, there can be no 'standard' seismic restraints solution. Most buildings involve extensive specialist architectural, geological, structural and services engineering and require specific design input to address their site, location, form and function.

A cost-effective and compliant solution is possible with a co-ordinated approach to design and procurement.

# 3

## AWCI seismic grade

In order to make the process of achieving a compliant ceiling system understandable to the wider industry, AWCINZ has established a seismic grading system for use at the early design stage.

Adopting a seismic grade allows designers to identify the extent to which a suspended ceiling is able to resist seismic forces and/or to remain intact in the event of an earthquake. The seismic grade applies to each ceiling, and it is conceivable that certain ceilings within a building will have a higher seismic grade than other ceilings in that building.

Each step up from the basic AWCI seismic grade 1 ceiling to the highest AWCI seismic grade 4 ceiling reflects an incremental step in grid strength, shop drawing requirements, the type and extent of seismic restraint, the requirement for specific engineering design and the involvement of independent seismic specialists.

There are a number of standards that are relevant to seismic restraints.

### **AS/NZS 2785:2000 Suspended ceilings – Design and installation**

This standard sets out minimum requirements for the design, construction, installation, maintenance and testing of internal and external non-trafficable suspended ceiling systems of dry construction with suspension systems attached to a supporting structure, for use in commercial, industrial and residential applications. It includes earthquake design requirements for ultimate limit state (ULS) and serviceability limit state (SLS) and when and where earthquake loads should be considered, by reference to NZS 1170.5:2004.

### **NZS 1170.5:2004 Structural design actions – Part 5: Earthquake actions – New Zealand**

This standard provides procedures for the determination of earthquake actions

on structures in New Zealand. It gives the requirements for verification procedures, site hazard determination, the evaluation of structural characteristics, structural analysis for earthquake action effects, the determination and limits for deformations and the seismic design of parts of structures. It is to be applied in conjunction with AS/NZS 1170 parts 0, 1, 2 and 3 relevant material standards.

### **NZS 4219:2009 Seismic performance of engineering systems in buildings (services only)**

This standard sets out the criteria for the seismic performance of engineering systems related to a building's function. It covers the design, construction and installation of seismic restraints for these engineering systems. Buildings with importance level 5, large mass items, structures external to the building, lifts, building contents and fire sprinkler systems are excluded from this standard.

### **IDENTIFYING THE AWCI SEISMIC GRADE OF A CEILING**

The first step in establishing the seismic grade of a ceiling (or ceilings) is to identify the geological, functional and engineering attributes, features or design factors that are relevant for the particular ceiling with regard to the requirements of the relevant New Zealand standards or other requirements.

The seismic grade of each ceiling is to be determined by the highest-scoring seismic grade (AWCI SG1 = lowest seismic grade, AWCI SG4 = highest seismic grade) based on the information available.

The ceiling designer will need to make conservative assumptions about the site subsoil category, building and ceiling risk category, building and ceiling ductility and period of vibration based on the information supplied.

Table 1: AWCi seismic grades for suspended ceilings.	
Seismic grade	Description
AWCI SG1	<ul style="list-style-type: none"> <li>Ceiling in a building with low seismic performance requirements with ceiling component category P7 and SLS1 (up to building importance level 3).</li> <li>Not requiring specific engineering design.</li> </ul>
AWCI SG2	<ul style="list-style-type: none"> <li>Ceiling in a building with low seismic performance requirements with ceiling component category P7 and SLS1 (up to building importance level 3).</li> <li>Within design parameters of relevant manufacturers' standard type-tested designs but not requiring specific engineering design.</li> <li>PS3 with supporting documents.</li> </ul>
AWCI SG3	<ul style="list-style-type: none"> <li>Ceiling in a building up to building importance level 3 or component category P4 where ceilings must be designed for ULS, in public spaces, forming part of an emergency egress way, supporting life safety systems or at high level.</li> <li>May be within design parameters of relevant manufacturers' standard type-tested designs, but specific engineering design is required.</li> <li>Minimum of PS1 and PS3 with supporting documents.</li> </ul>
AWCI SG4	<ul style="list-style-type: none"> <li>Ceiling in a building up to building importance level 4 or component category P4 where ceilings must be designed for ULS, in public spaces, forming part of an emergency egress way, supporting life safety systems or at high level.</li> <li>Specific engineering design is required.</li> <li>Minimum of PS1, PS3 with supporting documents and PS4.</li> </ul>

Additional information such as geotechnical reports or structural calculations for the building may allow for a more economical design, if these are available.

Ceiling seismic grades are set out in Table 1.

### COST CONSIDERATIONS

At the time of tendering, the actual requirements for each ceiling, having regard to its designated seismic grade and the requirements of the tender documents, should be checked.

Figure 1 demonstrates the incremental steps in the relative complexity and extent of engineering design and monitoring and consequentially the relative cost implications of the various seismic grades.

While compliance with NZBC seismic requirements can add cost, it will also limit damage, reduce repair costs, reduce the length of time for reoccupancy after a seismic event and minimise health and safety risks for occupants.

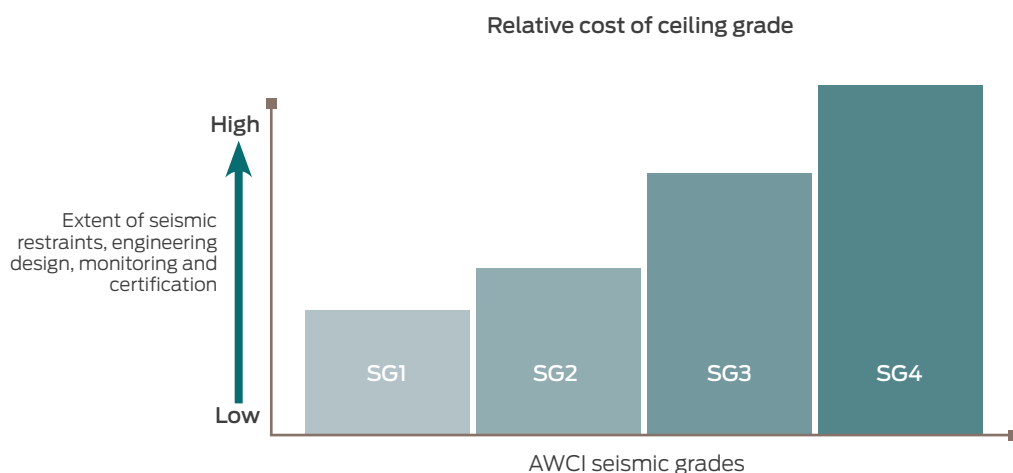

Figure 1: Change in relative cost of seismic requirements as complexity increases.

# 4

## Design

### THE DESIGN PROCESS

The opportunity to get the best design outcome is greatest early in the design process.

While the final product selection may not be known, the design parameters of all non-structural building elements should be outlined as early as possible so that all subcontractors are aware of the other trades.

The lead designer should be responsible for co-ordinating the design and installation of all subtrade equipment in the plenum and ceiling. The preferred approach, to ensure optimal co-ordination and productive use of resources, is for seismic design of non-structural components to be completed prior to the project going out to tender. Where a construction phase design process is used, the lead designer needs to specify the seismic grade of the ceiling and the associated seismic restraint requirements in the tender documents.

Ideally, construction documents should be delivered with a PS1 for the suspended ceiling design. This would show that the ceiling has been designed to the minimum structural requirements.

### DESIGN PRODUCER STATEMENT (PS1)

A PS1 is a statement of opinion that certain aspects of proposed building work will comply with the NZBC if the work is constructed according to the referenced documentation (for example, engineering design drawings and specifications).

The seismic design of suspended ceilings should be undertaken by a suitably qualified person with experience in ceiling design. If a manufacturer's generic seismic design guide is used, the working sheets should be submitted with the PS3.

### CONSTRUCTION PRODUCER STATEMENT (PS3)

A PS3 is certification from the suspended ceiling contractor that the ceiling has been installed in accordance with the relevant design, New Zealand standards and/or building consent as applicable.

Lead designers, BCAs, owners and insurers should be aware of the limitations of manufacturers' generic guidelines and assumptions made, for example, the structure(s) that the bracing points a ceiling is fixed to must be adequate to take the load.

It is important to note that, for retrofit/refurbishment, the lead designer needs to provide sufficient information on the structural detail, including loading capacity, of the building.

While, in some cases, actual product systems are specified by the designer, they can also be specified on a performance basis, leaving the tenderer free to offer whichever system they feel is able to meet the requirements. Further, the design of non-structural building elements often occurs after the building consent has been granted.

The seismic bracing system for these non-structural building elements is thus typically the responsibility of the contractor and their subcontractors.

Figure 2 shows a recommended project process from design to completed installation of a suspended ceiling system. Some steps may not be relevant for all projects. See Section 17, p65 for detail on producer statements.

### ROLES AND RESPONSIBILITIES OF THE PARTIES INVOLVED IN THE DESIGN

In most construction projects, there are many parties involved. All have different roles and

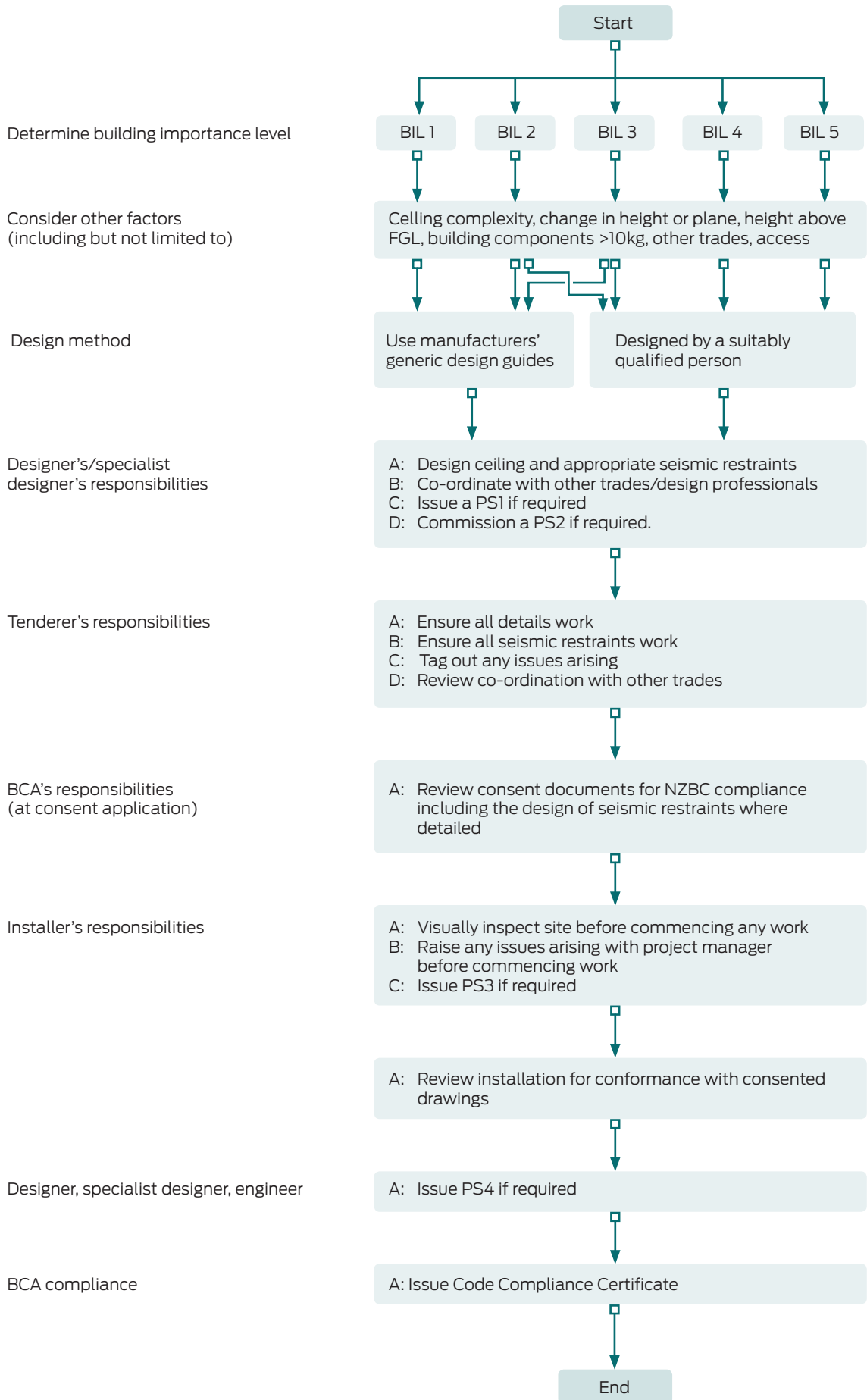

Figure 2: Recommended project process.

responsibilities, and in many steps of the process, the roles and responsibilities of several parties will overlap.

Table 2 shows, in general, the main steps in construction projects, the main parties involved and the stages where input from each party may be required. Table 3 defines the key roles involved.

## DESIGN CO-ORDINATION

Many view a suspended ceiling as a finished surface only and are unaware of the potential complexity of the design in the plenum. Consequently, they may not be aware of the possible true cost of a suspended ceiling system that has been designed to withstand earthquake actions.

Designers of other components in the plenum may have little regard to requirements of the ceiling support system.

The ceiling tenderer needs to establish what degree of co-ordination has taken place between the other suppliers of building components in the plenum in terms of their design, engineering calculations and installation processes.

Design co-ordination is possibly the single biggest issue facing suspended ceiling work. In general, the better co-ordination prior to issuing tender documents:

- the more accurate a costing can be achieved
- the better the installation process will be
- there will be fewer site variations
- there will be an overall lower total cost
- there will be fewer time delays during installation
- there will be fewer site conflicts.

## OTHER TRADES IN THE PLENUM

### Seismic restraint of non-structural building components other than ceilings

It is an NZBC requirement that non-structural building components must be properly restrained against earthquake actions to prevent them collapsing on people, cutting off exit routes from the building, being damaged or damaging other property.

The seismic design and compliance of building components in the plenum space are the responsibility of their respective designer, with the most common way of meeting the NZBC requirements being the use of Verification Method B1/VM1.

B1/VM1 cites New Zealand standard NZS 4219:2009, which contains prescriptive and specific engineering design options for restraining engineering systems, including items interrelated with suspended ceilings.

There are a wide range of non-structural building components that can be located in the plenum or below, including but not limited to:

- sprinkler systems
- air-conditioning ducts
- cabling ducts
- lighting systems, including their support
- ceiling-height partition walls
- bracing for ceiling-height partition walls
- full-height partition walls
- mechanical installations for access
- telecommunications cabling
- office equipment suspended from the ceiling system, for example, overhead projectors, security cameras, ceiling fans, alarm systems, air-conditioner cassettes, drop-down projector screens, signage, speakers and fire alarm systems.

### Who does the design for other building components?

The layout of building components in the plenum needs to be co-ordinated so that any one component does not impede or interfere with another, for example:

- the need to allow 25 mm free movement around sprinkler droppers can be eliminated by using flexible hose droppers
- careful consideration is required to ensure that elements such as light fittings and diffusers supported by the ceiling are independently supported unless under allowable weight limits – refer to relevant standards.

### Co-ordination of design

Ideally, the lead designer should be responsible for co-ordinating non-structural building components in the plenum so that there are no conflicts.

Checklist to complete before tender shall include:

- bracing layout
- edge details
- services
- proof of co-ordination and location of services
- suspended ceiling plan overlaid with services and plenum
- suspension points identified that are clear of services
- unrestrained/restrained services
- maximum lateral displacement.



<b>Table 2: Main steps and parties that may be involved.</b>						
	Design	Compliance design	Tendering	Contract	Installation	Completion
Client	✓			✓		✓
Project manager	✓		✓	✓	✓	✓
Lead designer	✓	✓	✓		✓	✓
Specialist designer	✓	✓	✓		✓	✓
Engineer	✓	✓			✓	✓
Main contractor	✓	✓	✓	✓	✓	✓
Suspended ceiling contractor	✓	✓	✓	✓	✓	✓
Other trades	✓	✓	✓	✓	✓	✓
Supplier	✓	✓			✓	✓
Building consent authority		✓			✓	✓

<b>Table 3: Definitions.</b>	
Client	The entity parties are contracted to.
Project manager	A person or company who will have an overview of the whole project, which may include co-ordination of the design team.
Lead designer	May be an architect, interior designer or engineer. The lead designer oversees the entire documentation process. Historically, this has been an architect, but more recently and depending on the nature of the project, other suitably qualified people have been taking on this role.
Specialist designer	Each component in the plenum may have their own specialist designer.
Engineer	A suitably qualified structural engineer.
Main contractor	The company that has contracted to build the entire project and is responsible for overseeing and co-ordinating all on-site trades and the construction programme.
Suspended ceiling contractor	The company that will be carrying out the installation and, in some circumstances, installation design.
Other trades	Other trades that may have non-structural building components being installed in the plenum such as air-conditioning ducts, fire protection systems or lighting fixtures.
Supplier	The company supplying the product for installation.
Building consent authority	Where required, the organisation that will grant a building consent, carry out inspections as necessary and, at completion, issue a Code Compliance Certificate.

# 5

## Design documentation

The design and construction of a successful building requires the successful integration of a range of inputs, with one key factor being that the construction documentation must be well co-ordinated. Design documents provide the critical link between all parties in a building project so that everyone knows what is being built, where it is being put, when it will be done and how it is done. The better the documentation, the better the outcome will be.

With respect to suspended ceilings and all components and services in the plenum, design documentation should:

- clearly define design parameters and responsibilities from the outset and communicate these to all parties involved in the project
- enable everyone to identify anything that may impact on their part of the project
- give consistent information and specify critical datum point measurements – for suspended ceilings, the set-out point and design criteria are critical
- show where other components in the plenum will be located and their fixing points – 3D schematics would help to show any issues that may arise at the points of intersection
- specify the co-ordination of the installation sequencing.

The use of technology such as building information modelling (BIM) should also be considered.

### COMPLIANCE WITH NZBC AND STANDARDS

NZBC clause B1 *Structure* requires that all building elements must have a low probability of failure when exposed to loads likely to be experienced within their lifetime. Compliance with the NZBC can be achieved through Acceptable Solutions, Verification Methods or using Alternative Solutions. There are no published Acceptable Solutions for

suspended ceilings, and therefore Verification Methods are almost always used.

Verification Method B1/VM1 provides a means for the design of structures to meet the performance requirements of NZBC clause B1 *Structure*. Within B1/VM1, there are numerous standards referenced that relate to suspended ceilings and engineering systems likely to be encountered in any building.

For engineering systems and non-structural building components, the most common Verification Methods for earthquake restraint are:

- NZS 4219:2009 *Seismic performance of engineering systems in buildings*
- NZS 1170.5:2004 *Structural design actions – Part 5: Earthquake actions – New Zealand* and the relevant product standard, for example, AS/NZS 2785:2000 *Suspended ceilings – Design and installation* or NZS 4541:2013 *Automatic fire sprinkler systems*
- AS/NZS 4600:2005 *Cold-formed steel structures*.

The Verification Method includes New Zealand-specific modifications to the referenced standards, which will need to be complied with as part of the design process.

### SEISMIC DESIGN

In addition to gravity forces, earthquake forces acting in vertical or horizontal directions must be considered for suspended ceilings in New Zealand to comply with AS/NZS 2785:2000 and NZS 1170.5:2004.

There are three fundamental seismic layout concepts (Figure 3):

1. Perimeter connecting on two adjacent walls and two walls floating.
2. Perimeter connecting at all four sides with 'seismic separation' to allow for movement.
3. Floating on all sides, braced to the structure.

Regardless of type of ceiling used, if ceiling systems bridge dissimilar structures or if there is a seismic joint in the building, seismic joints must be allowed for.

### Perimeter fixing

Perimeter fixing of ceilings is normally restricted to 'small' rooms, the size of which will depend upon, but not be limited to:

- the seismic forces to be accommodated
- the capacity of the ceiling grid and perimeter fixing components to transfer load
- the capacity of the perimeter fixings to accommodate lateral movement
- the capacity of the perimeter walls to transfer loads.

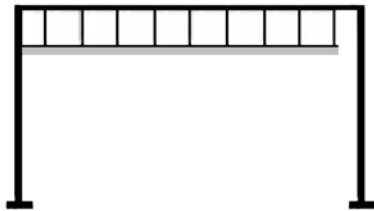

1. Perimeter fixing

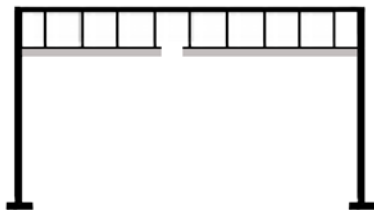

2. Perimeter fixing with seismic separation break

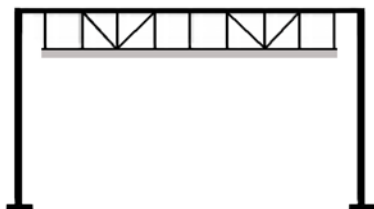

3. Floating on all sides, braced to the structure

**Figure 3: Seismic layout concepts.**

4 The ultimate limit state (ULS) is reached when the applied stresses actually exceed the strength of the structure or structural elements, causing it to fail or collapse.

5 The serviceability limit state (SLS) is the point where a structure can no longer be used for its intended purpose but would still be structurally sound.

Perimeter fixing can be either fixed or free/sliding. The determination of whether the perimeter fixing is free or sliding will depend upon not only the above factors but many other factors as well. A minimum of two adjoining sides will be fixed, and in some instances, all four sides may be fixed.

Vertical restraint is usually provided by the self-weight of the suspended ceiling in the downward direction. Rigid hangers or compression type struts may be required depending on seismic zone, wind loading, floor to ceiling height and plenum height.

### Seismic forces

Seismic forces are the actions developed during an earthquake and are determined in accordance with NZS 1170.5:2004 and applied in the limit state design of both structures and parts. Within the scope of NZS 1170.5:2004, ceilings are specified under 'parts'.

### Braced ceilings

Bracing of ceilings is a solution for 'large' rooms or open areas where there are limited partition walls to restrain the ceiling grid.

The bracing is generally installed on a uniform and regular grid pattern, the spacing of which will depend upon, but not be limited to:

- the seismic forces to be accommodated
- the capacity of the ceiling grid and bracing systems to transfer load
- the density of the services located within the ceiling plenum space.

B1/VM1 provides a procedure and criteria to determine both ultimate limit state (ULS)<sup>4</sup> and serviceability limit state (SLS)<sup>5</sup> seismic actions. Most manufacturers provide a simplified conservative method of calculating the seismic forces, in accordance with the standards requirements.

The reliance on manufacturers' data will require intimate knowledge of the limitations in the data by the ceiling installer. In some instances, the generic data provided by the manufacturer can be used up to and including ceiling systems in seismic grade 3 (SG3) (see section 3) depending on the size and complexity of the project. However, it should be noted that a Chartered Professional Engineer, registered in New Zealand (CPEng), will still need to be engaged for SG3 ceiling systems.

## CLASSIFICATION OF PARTS

The classification of building parts (Table 4) is a key step in the determination of the seismic actions, in accordance with NZS 1170.5:2004 section 8.

Traditionally, ceiling systems have been classified under P7 – All other parts, with the exception of those ceilings installed in buildings of importance level 4 or greater.

Currently, most light suspended ceilings are classified as P7 – which only requires design for serviceability, for an SLS1 earthquake.

Table 8.1 of NZS 1170.5:2004 does not explicitly define the various ceiling systems likely to be installed in the buildings. Rather, it provides risk criteria, a risk factor ( $R_p$ ) and a limit state for design. Fundamentally, although not explicitly

defined, the underlying risk for ceiling systems lies in both mass and height above personnel. With this in mind, it is recommended that any light suspended ceiling that provides support to P4 components (for example, emergency lights, exit signs, smoke/fire detectors, fire sounders/evacuation speakers and sprinklers connected via proprietary flexible droppers) or is above escape routes (a continuous unobstructed route from any occupied space to a final exit) must be classified as P4 and designed for ULS.

Table 4: Classification of building parts.			
Building component	Criteria		Structure limit state
P1	Part representing a hazard to life outside the structure	Part weighing more than 10 kg and able to fall more than 3 metres onto a publicly accessible area	ULS
P2	Part representing a hazard to a crowd of greater than 100 people within the structure	Part weighing more than 10 kg and able to fall more than 3 metres onto a publicly accessible area	ULS
P3	Part representing a hazard to individual life within the structure	Part weighing more than 10 kg and able to fall more than 3 metres onto a publicly accessible area	ULS
P4	Part necessary for the continuing function of the evacuation and life safety systems within the structure		ULS
P5	Part required for the operational continuity of the structure	Only parts essential to the operational continuity of structures with importance level 4 will be classified as P5 – non-essential parts and parts within structures of other importance levels will be otherwise classified	SLS2
P6	Part for which the consequential damage caused by its failure is disproportionately great		SLS1
P7	All other parts		SLS1

## BUILDING IMPORTANCE LEVEL

B1/VM1 (which references AS/NZS 1170.0:2002 Appendix 2) defines building importance levels as shown in Table 5 below. The building importance level (IL) shall be nominated on the design documentation.

Table 5: Building importance levels.		
Importance level	Description of building type	Specific structure
1	Buildings posing low risk to human life or the environment or a low economic cost should the building fail. These are typically small non-habitable buildings, such as sheds, barns and the like that are not normally occupied, though they may have occupants from time to time.	<ul style="list-style-type: none"> <li>• Ancillary buildings not for human habitation</li> <li>• Minor storage facilities</li> <li>• Backcountry huts</li> </ul>
2	Buildings posing normal risk to human life or the environment or a normal economic cost, should the building fail. These are typical residential, commercial and industrial buildings.	<ul style="list-style-type: none"> <li>• All buildings and facilities except those listed in importance levels 1, 3, 4, and 5</li> </ul>
3	Buildings of a higher level of societal benefit or importance or with higher levels of risk-significant factors to building occupants. These buildings have increased performance requirements because they may house large numbers of people, vulnerable populations or occupants with other risk factors or fulfil a role of increased importance to the local community or to society in general.	<ul style="list-style-type: none"> <li>• Buildings where more than 300 people congregate in 1 area</li> <li>• Buildings with primary school, secondary school, or daycare facilities with a capacity greater than 250</li> <li>• Buildings with tertiary or adult education facilities with a capacity greater than 500</li> <li>• Health care facilities with a capacity of 50 or more residents but not having surgery or emergency treatment facilities</li> <li>• Jails and detention facilities</li> <li>• Any other building with a capacity of 5,000 or more people</li> <li>• Buildings for power generating facilities, water treatment for potable water, wastewater treatment facilities, and other public utilities facilities not included in importance level 4</li> <li>• Buildings not included in importance level 4 or 5 containing sufficient quantities of highly toxic gas or explosive materials capable of causing acutely hazardous conditions that do not extend beyond property boundaries</li> </ul>

Continued over page

From previous page

<b>Table 5: Building importance levels.</b>		
<b>Importance level</b>	<b>Description of building type</b>	<b>Specific structure</b>
4	Buildings that are essential to post-disaster recovery or associated with hazardous facilities.	<ul style="list-style-type: none"> <li>• Hospitals and other health care facilities having surgery or emergency treatment facilities</li> <li>• Fire, rescue, and police stations and emergency vehicle garages</li> <li>• Buildings intended to be used as emergency shelters</li> <li>• Buildings intended by the owner to contribute to emergency preparedness, or to be used for communication, and operation centres in an emergency, and other facilities required for emergency response</li> <li>• Power generating stations and other utilities required as emergency backup facilities for importance level 3 structures</li> <li>• Buildings housing highly toxic gas or explosive materials capable of causing acutely hazardous conditions that extend beyond property boundaries</li> <li>• Aviation control towers, air traffic control centres, and emergency aircraft hangars</li> <li>• Buildings having critical national defence functions</li> <li>• Water treatment facilities required to maintain water pressure for fire suppression</li> <li>• Ancillary buildings (including, but not limited to, communication towers, fuel storage tanks or other structures housing or supporting water or other fire suppression material or equipment) required for operation of importance level 4 structures during an emergency</li> </ul>
5	Buildings whose failure poses catastrophic risk to a large area (e.g. 100 km <sup>2</sup> ) or a large number of people (e.g. 100,000).	<ul style="list-style-type: none"> <li>• Major dams</li> <li>• Extremely hazardous facilities</li> </ul>

# 6

## Ceiling types and components

This section looks at ceiling fixing methods, ceiling systems, bulkheads and ceiling components.

### CEILING FIXING METHODS

There are two main ceiling fixing methods:

- Directly hung ceilings have main runners or tees directly suspended from the building structure.
- Indirectly hung ceilings are less common and have intermediate carrying channels directly suspended from the building structure.

### CEILING SYSTEMS

Ceiling suspension systems come in a variety of forms, but the main common varieties are:

- grid and tile
- framework for plasterboard or other sheeted products
- specialty feature ceilings.

#### Two-way exposed

Main tee and cross tees exposed with lay-in acoustical panels. They are available as 24 mm or 15 mm wide visible faces.

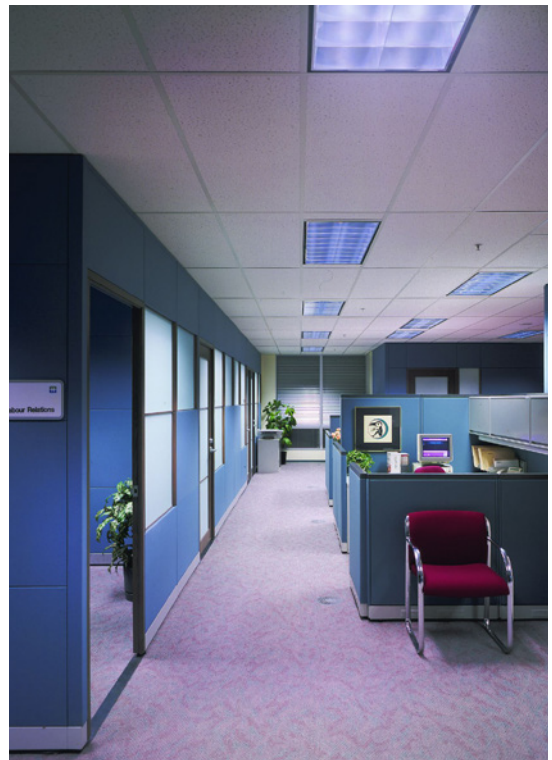

Figure 4: Exposed grid and tile system in place.

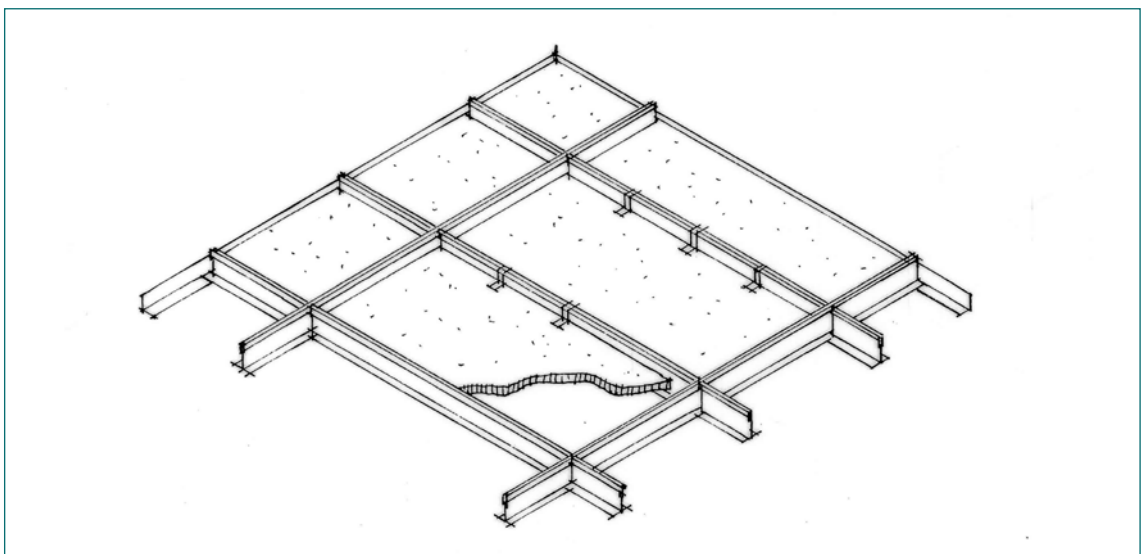

Figure 5: Schematic diagram of two-way grid.

**One-way exposed**

Main tee exposed, cross tees concealed by fully kerfed acoustical panel with splines.

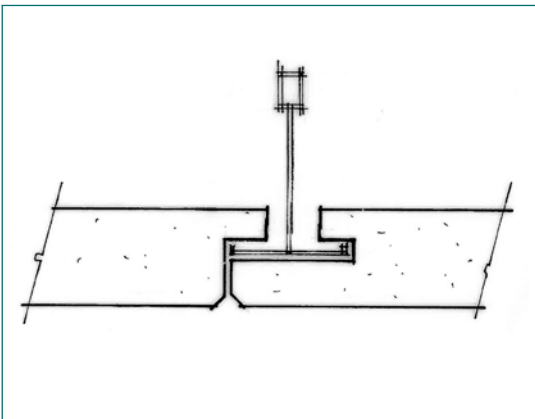

Figure 6: Concealed edge.

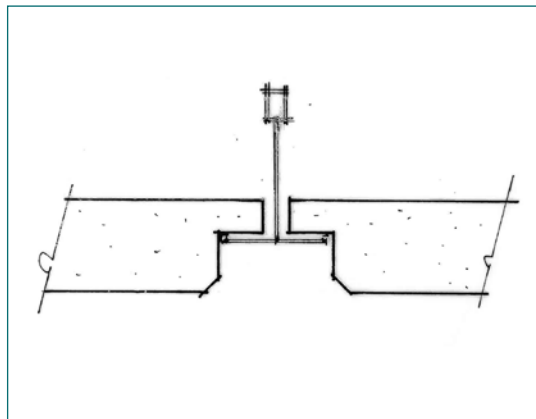

Figure 7: Tee grid visible in only one direction.

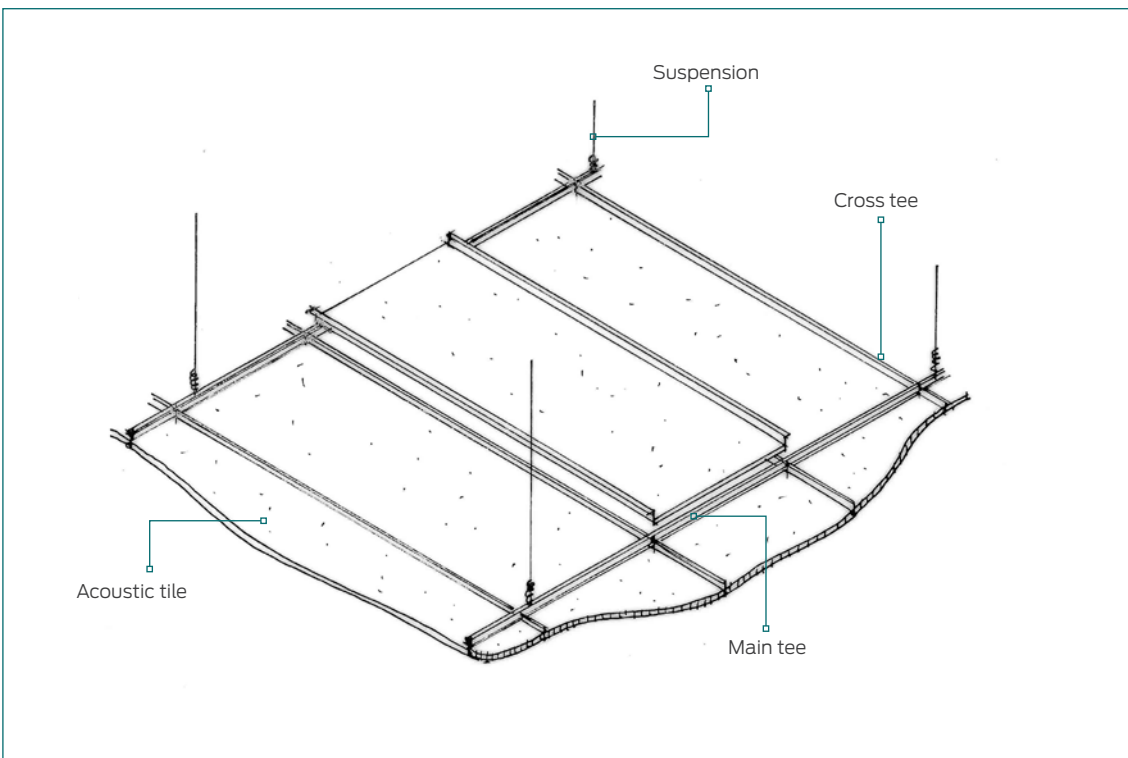

Figure 8: Schematic diagram of one-way exposed grid.



**Fully concealed**

For fully concealed grid systems, the main tee, cross tees and splines are concealed by fully kerfed acoustical tiles.

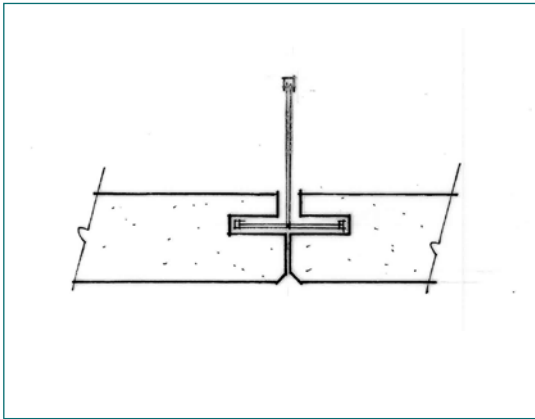

Figure 9: Back-to-back L splines.

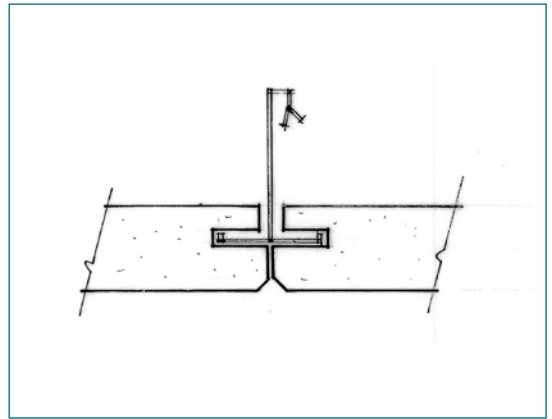

Figure 10: C and Z splines.

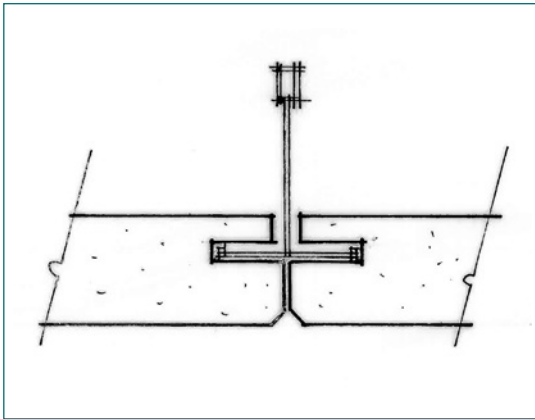

Figure 11: Tee grid.



Figure 12: Concealed grid.

**Plasterboard or other sheet-lined suspension systems**

Steel framing systems expressly designed for attaching sheet linings such as plasterboard, fibrous plaster and fibre cement.

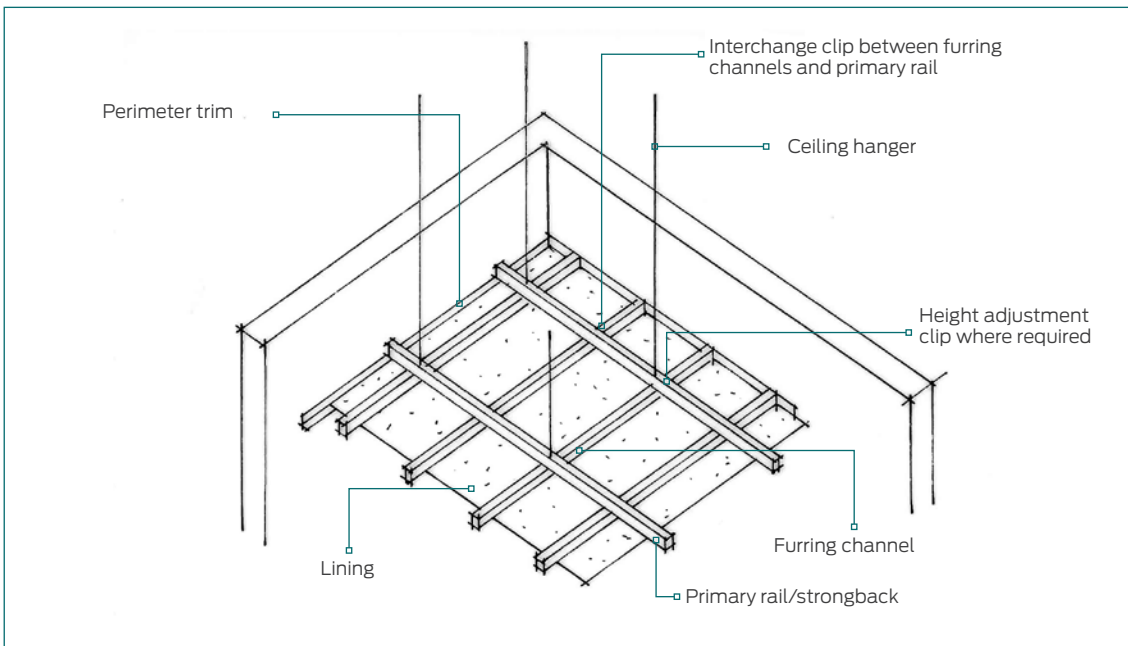

Figure 13: Suspended sheeted or flush ceiling grid system.

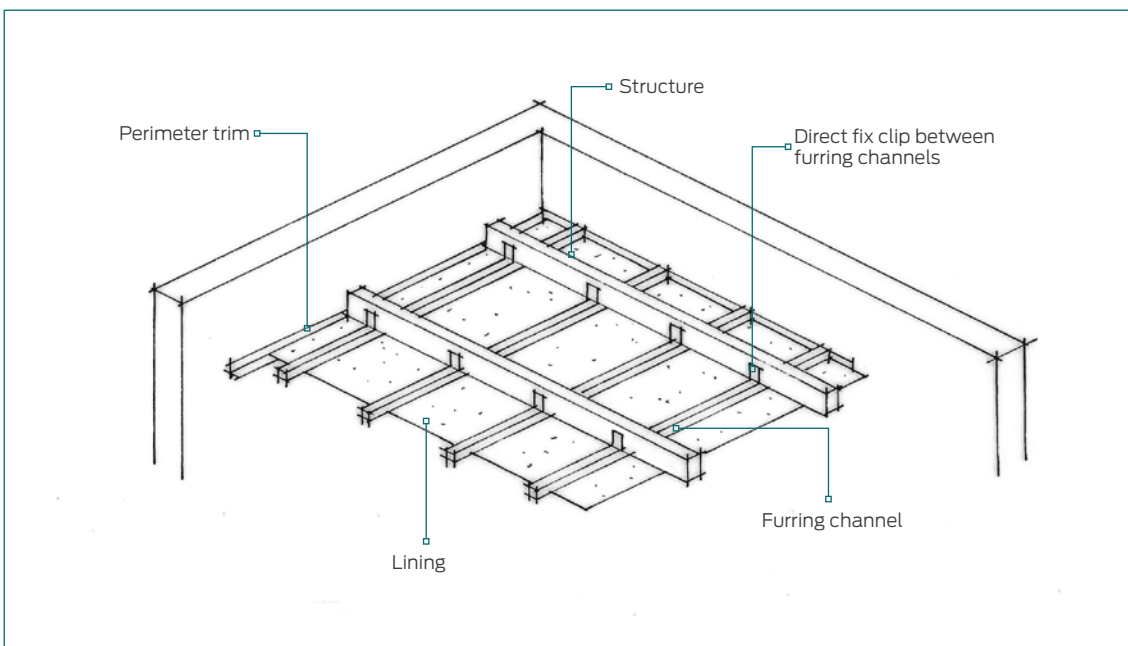

Figure 14: Direct fix sheeted or flush ceiling system.

### Specialty or feature ceilings

These allow the designer to create custom design far beyond the usual limits of standard ceilings. Specialty ceilings give the ability for unique innovative installations.



Figure 15: Finished feature ceilings.

## Linear and metal

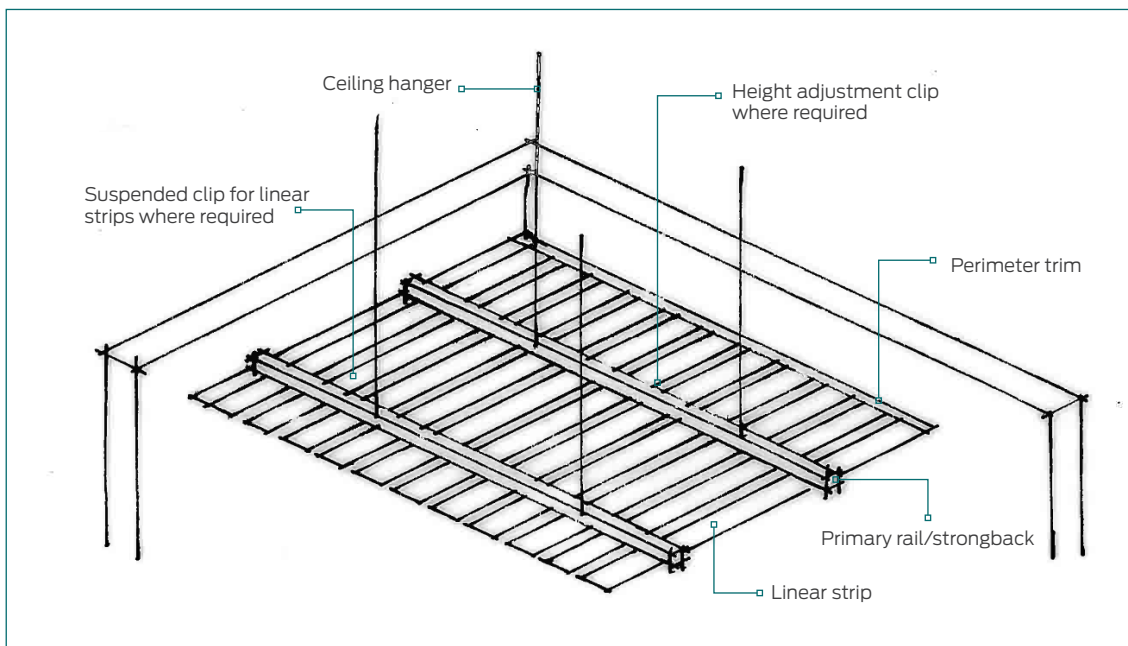

Figure 16: Suspended linear or strip ceiling system.

### Curved ceilings

May be curved in one, two or three dimensions.  
Panels may be formed or flat and flexible to conform to the curve of the ceiling.

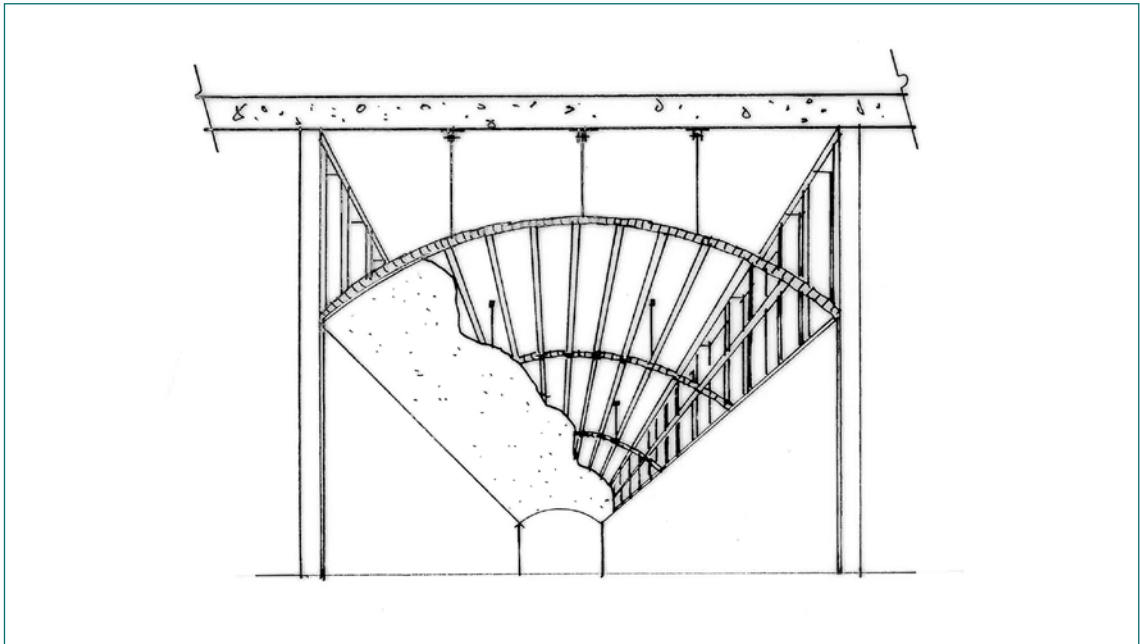

Figure 17: Curved ceiling schematic.



Figure 18: Proprietary linear ceiling system.

**Floating cloud**



**Ceilings below other ceilings**



Figure 20: Feature ceiling below another ceiling.



Figure 19: Floating cloud ceilings.

### Wind loads

Wind loads should be considered with all ceilings.

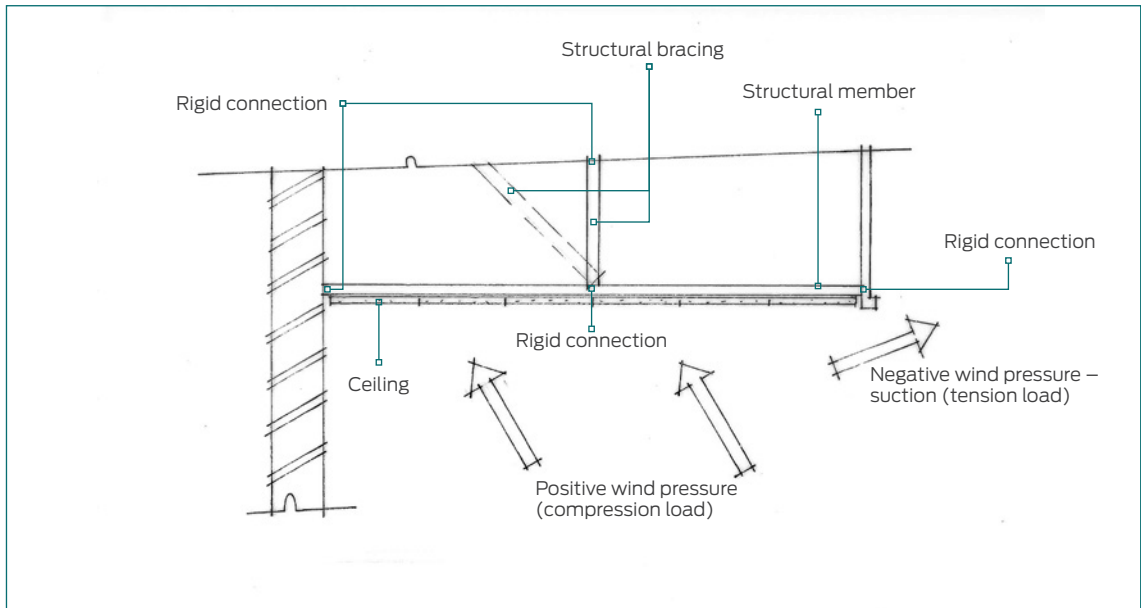

Figure 21: Wind loads.

## BULKHEADS

Bulkheads are typically used to create boxed-in areas to conceal structural elements/services or to separate ceilings of differing heights.

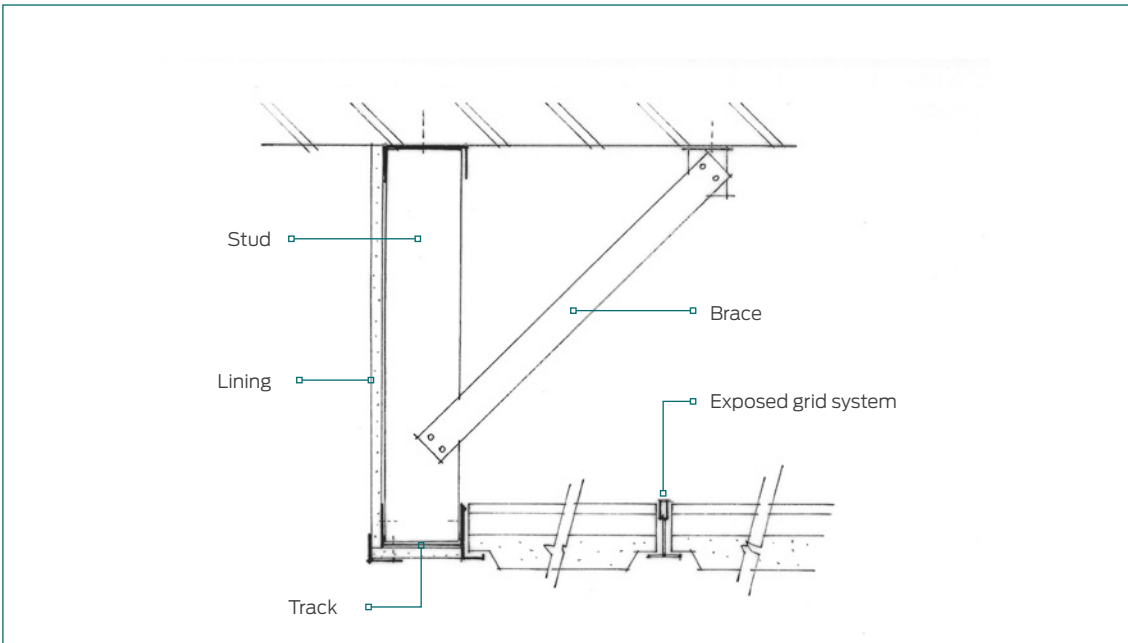

Figure 22: Bulkhead off solid underfloor.

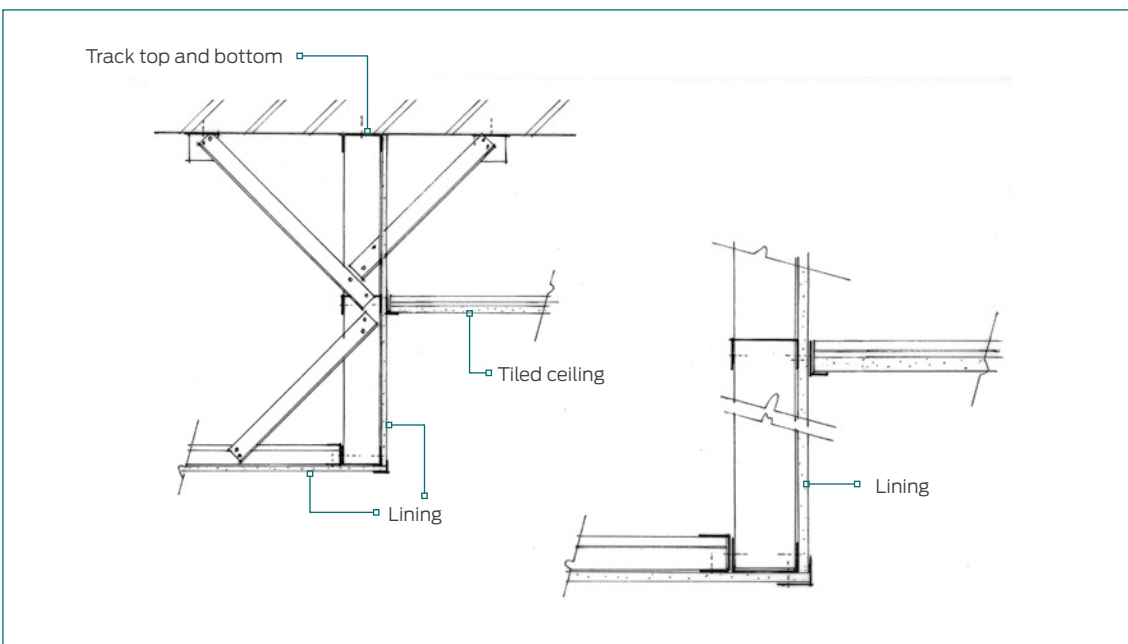

Figure 23: Bulkhead off solid underfloor with two ceilings at different heights.



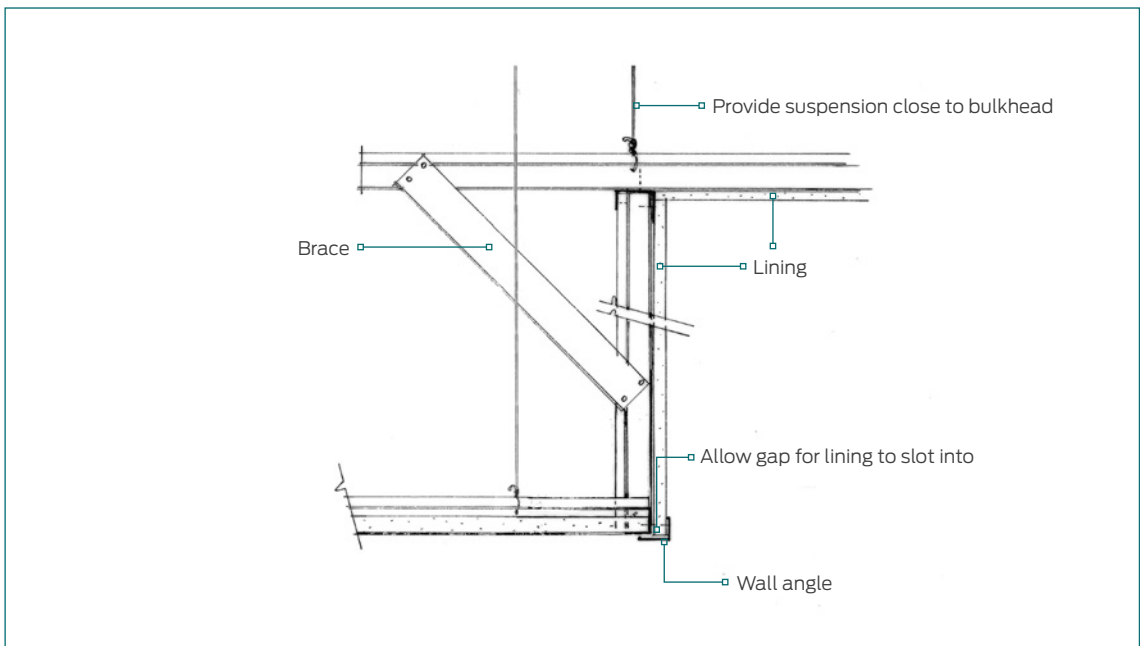

Figure 24: Suspended ceiling and bulkhead, cantilevered top ceiling support.

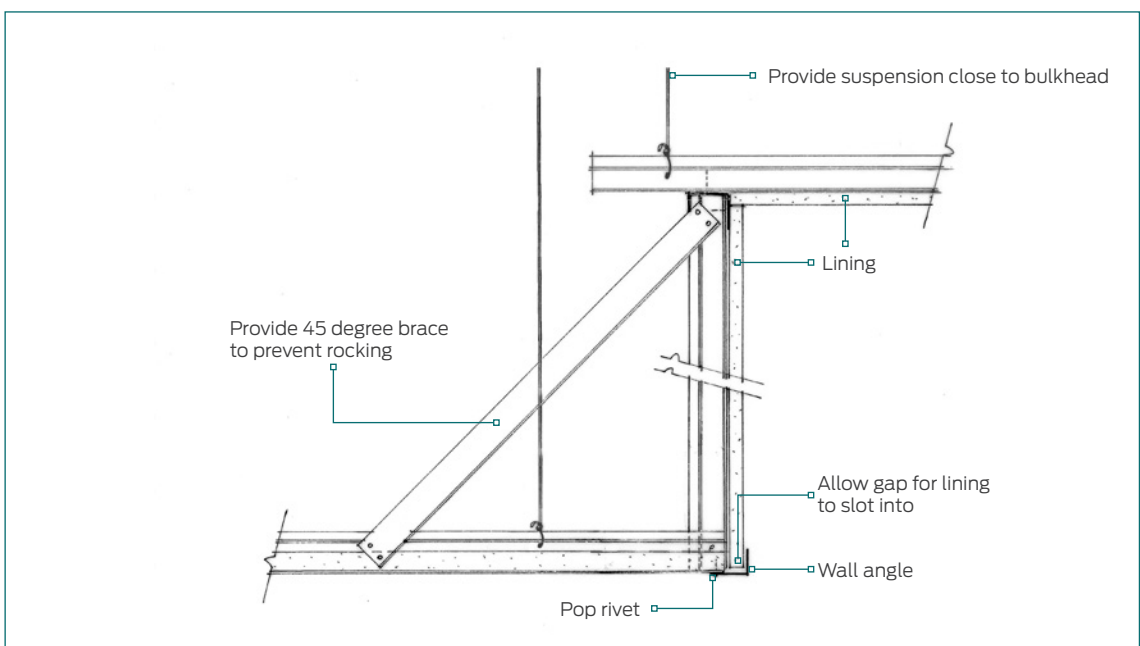

Figure 25: Suspended ceiling and bulkhead.

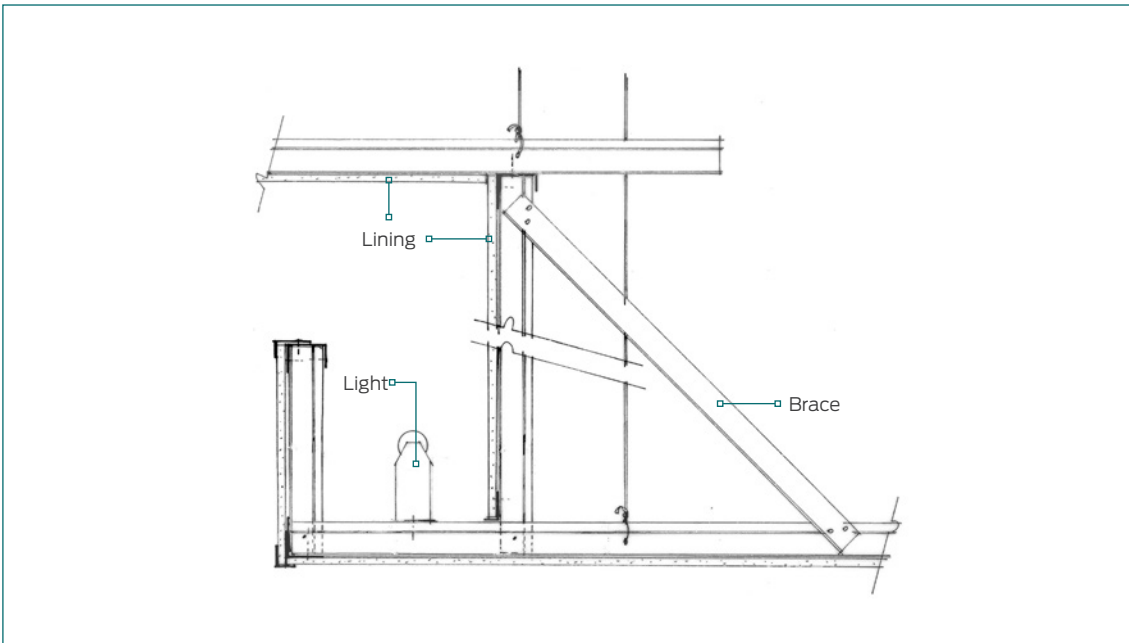

Figure 26: Suspended ceiling and light trough bulkhead.

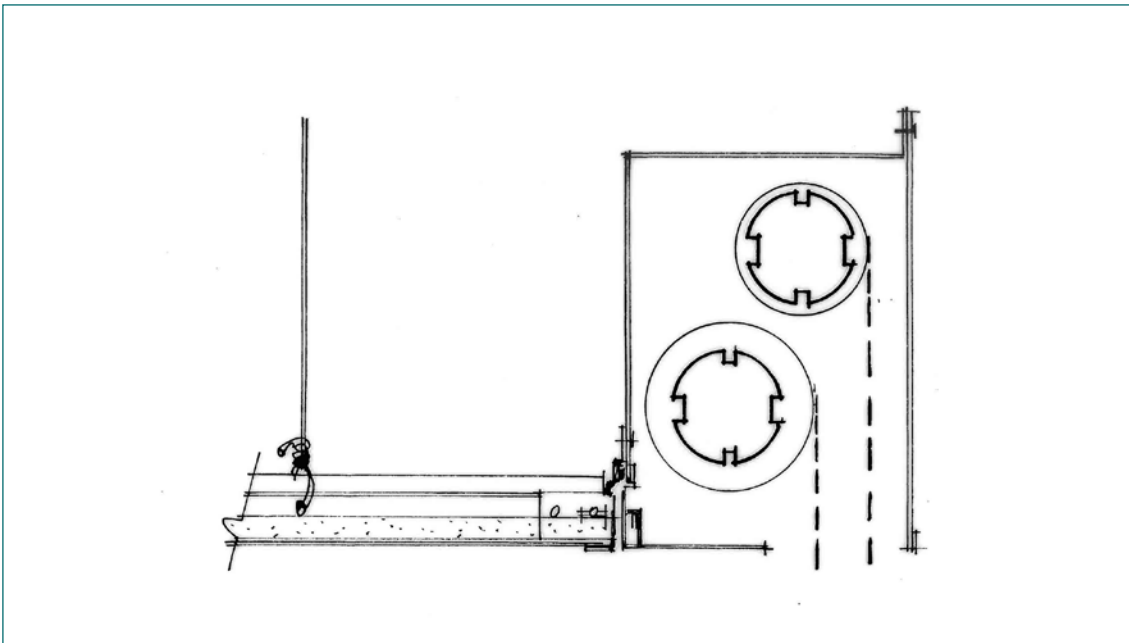

Figure 27: Suspended ceiling to blind box detail.

## CEILING COMPONENTS

### Wall trims and perimeter channels

Trims and channels are available in varying profiles to match the grid.

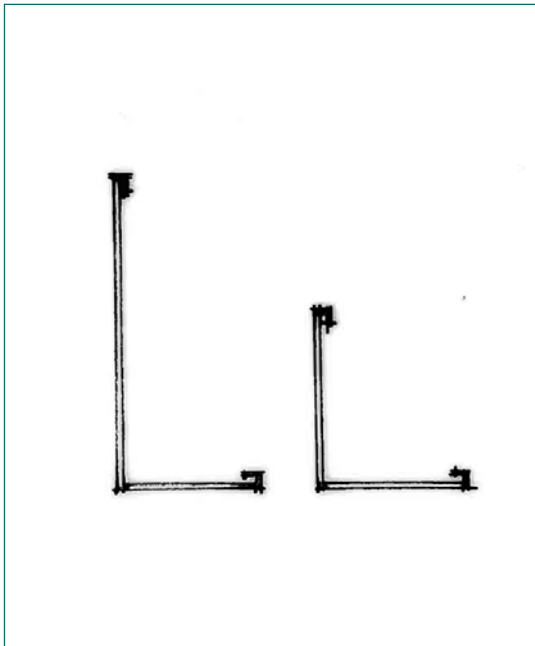

Figure 28: L trims, various sizes, equal and unequal leg length.

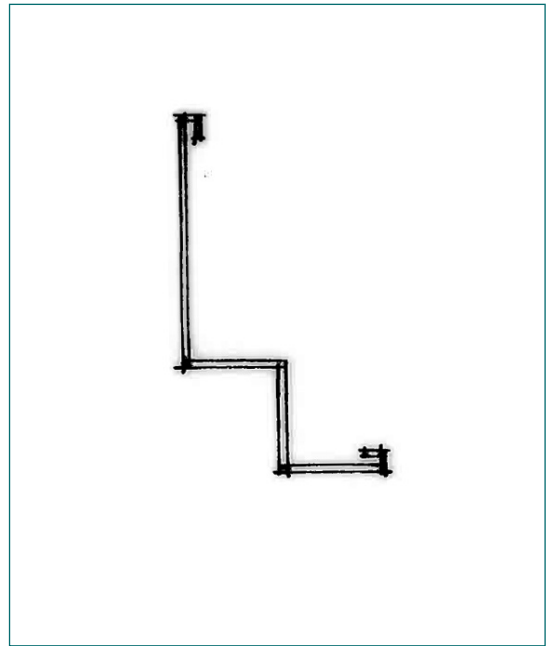

Figure 29: Shadow trims, various sizes.

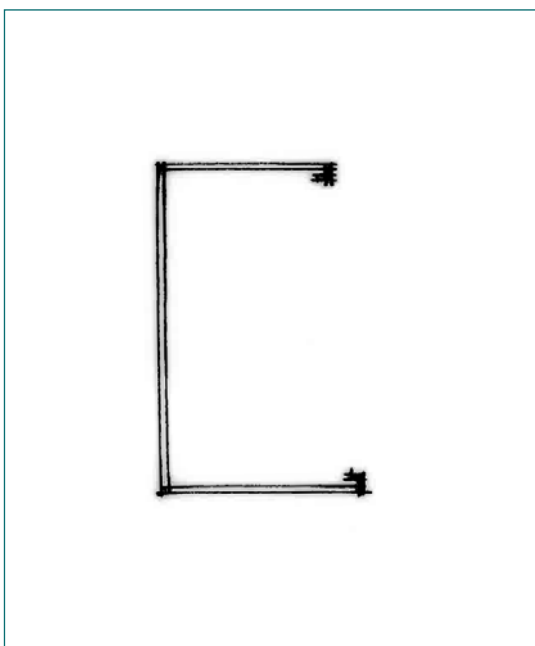

Figure 30: C channels, various sizes.

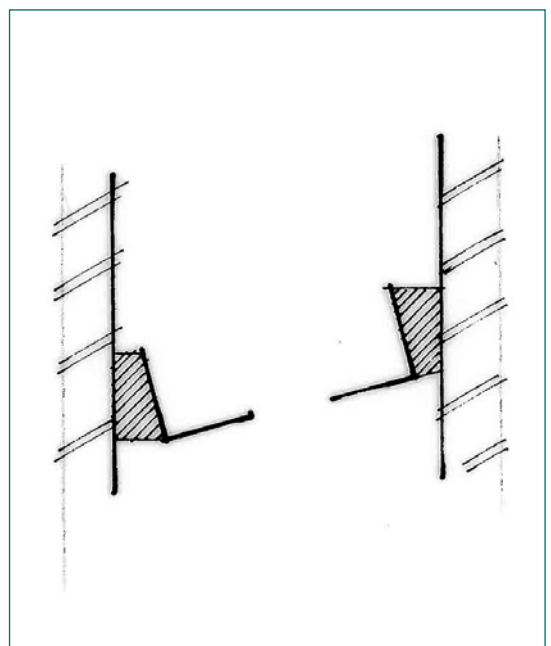

Figure 31: Wall shims, used at edges of ceilings to accommodate sloped ceilings.

### Fixing clips

Providing connection options that allow some expansion movement within a perimeter-attached suspended ceiling.

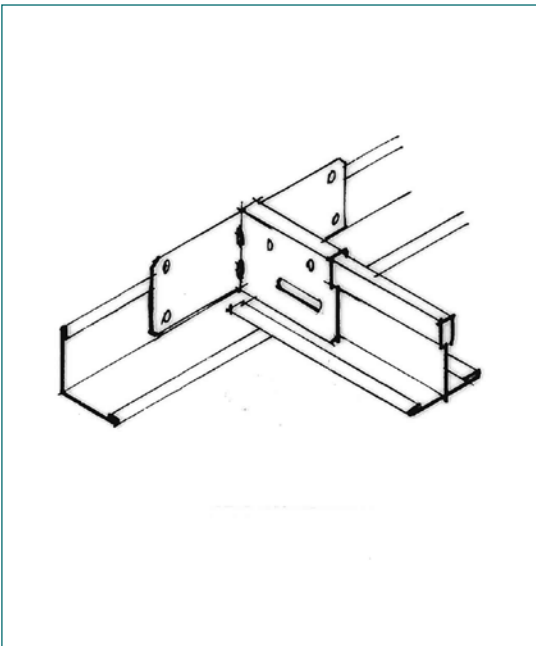

Figure 32: Perimeter clips.

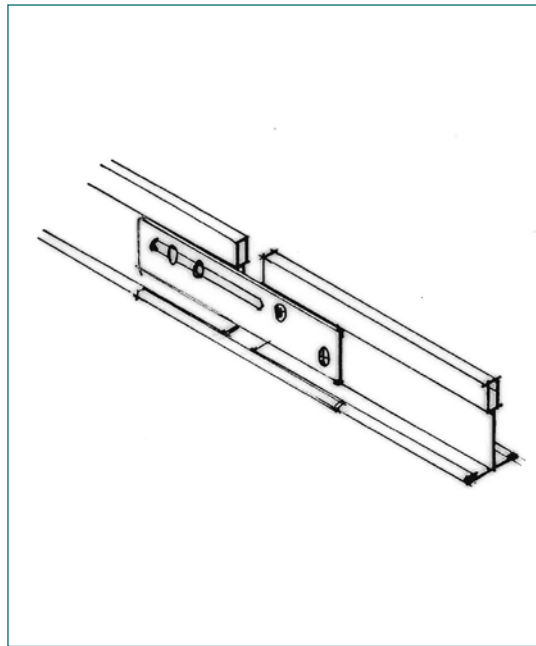

Figure 33: Main beam joint clip.

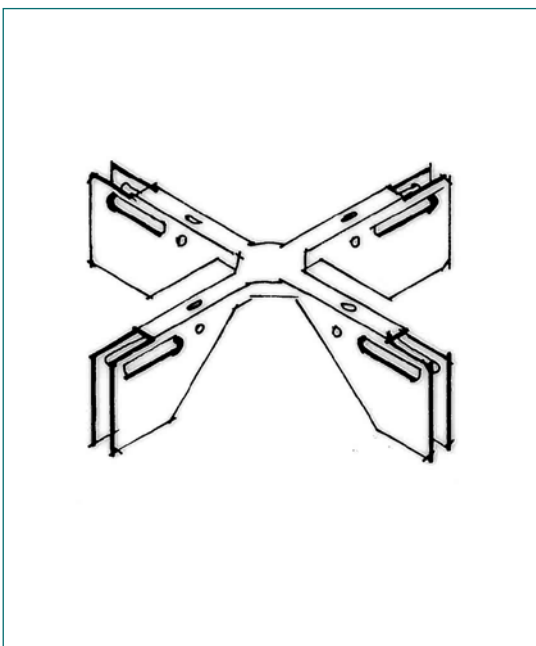

Figure 34: Cross tee joint clip.

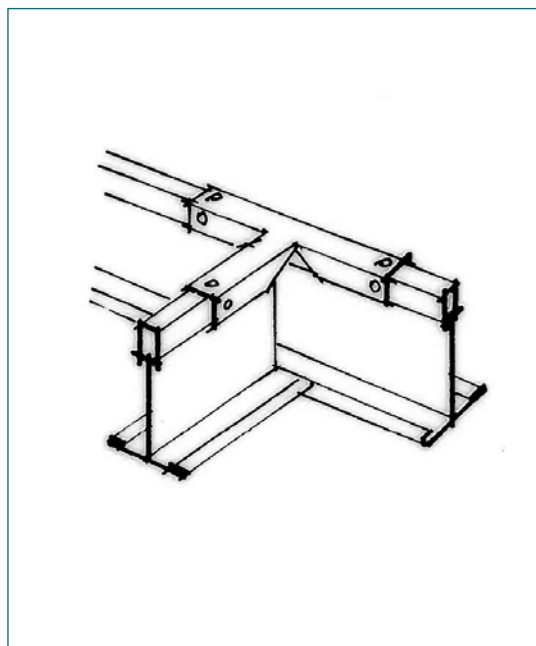

Figure 35: Three-way cross joint clip for off-module connection.

**Main tees**

Standard length is 3600 mm. Other non-standard sizes may be project specified and manufactured to order. Available with a 24 mm

or 15 mm visible face. Imperial sizes for refurbishment are also available.

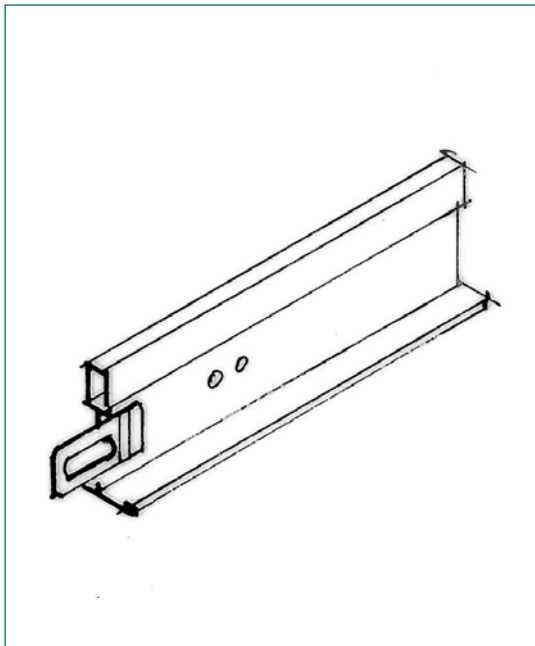

Figure 36: Main tee, 24 mm face.

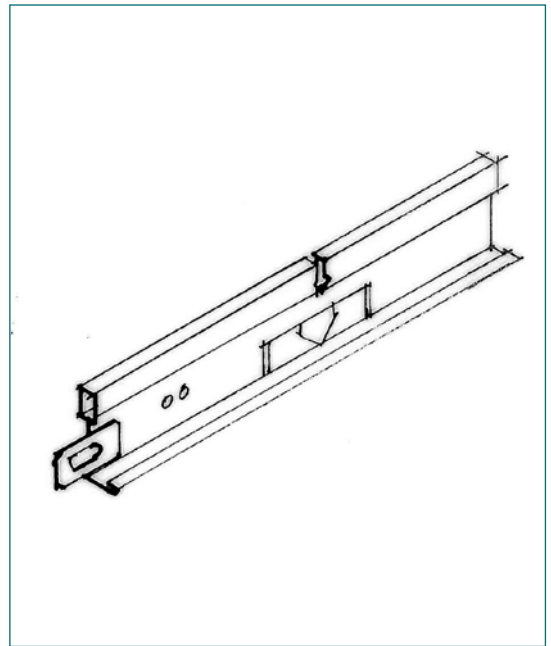

Figure 37: Fire-rated main tee, 24 mm face.

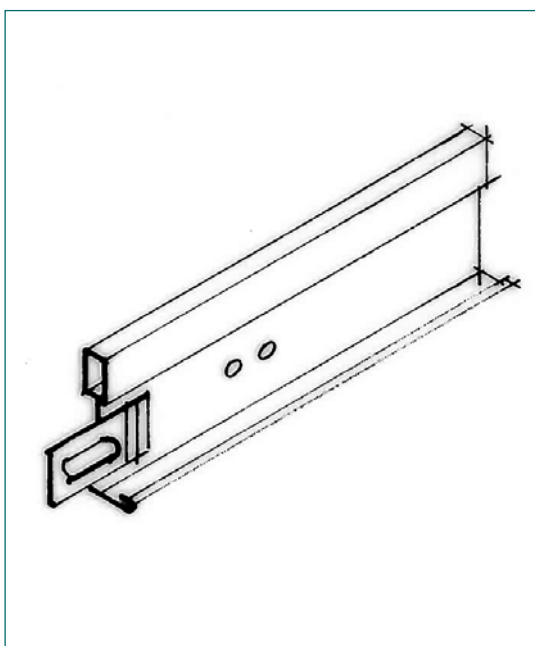

Figure 38: Main tee, 15 mm face.

### Cross tees

Standard lengths are 1200 mm and 600 mm. Other non-standard sizes may be project specified and manufactured to order. Available

with a 24 mm or 15 mm visible face. Imperial sizes for refurbishment are also available.

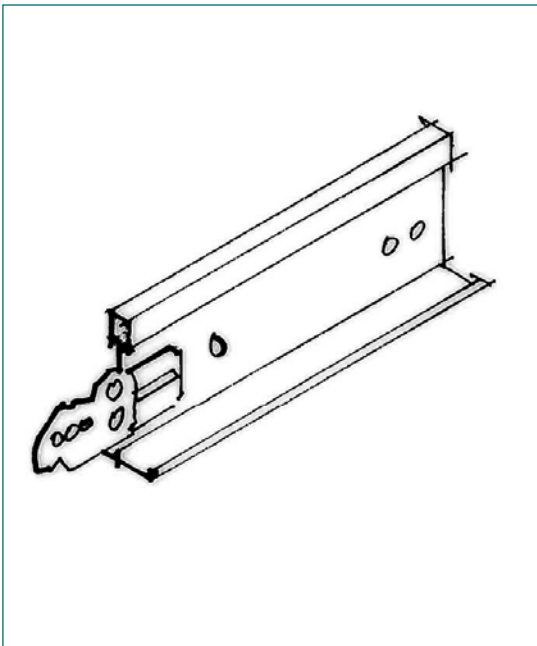

Figure 39: Cross tee, 24 mm face.

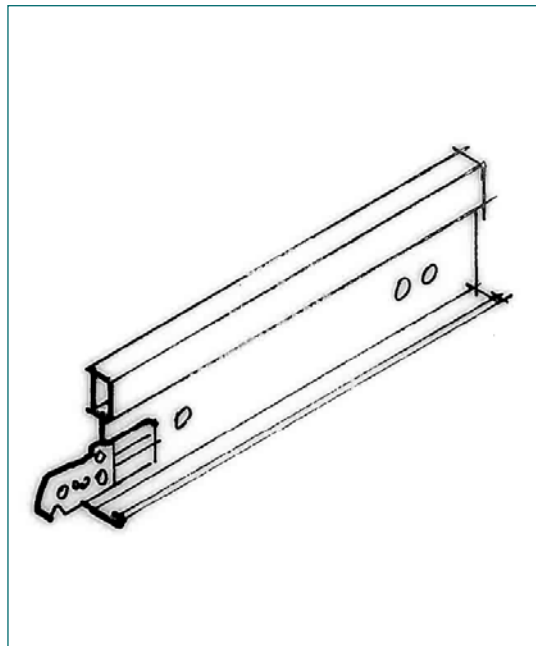

Figure 40: Cross tee, 15 mm face.

# 7

## Testing of product

The relevant standards to prove compliance for New Zealand conditions include, but are not limited to:

- AS 1397-2011 *Continuous hot-dip metallic coated steel sheet and strip – Coatings of zinc and zinc alloyed with aluminium and magnesium*
- AS/NZS 4600:2005 *Cold-formed steel structures.*

A minimum of 10 standard production samples shall be tested to ensure a fair representation of what variability products achieve. Minimum failure values shall apply (not the average). Variability factors shall be applied (AS/NZS 4600:2005 Table 6.2.2.) subject to the actual number of samples tested.

# 8

## Manufacturers' generic seismic design guides

Global suspended ceiling manufacturers provide generic seismic design guides that calculate the seismic design detail requirements for many common non-SED ceiling installation situations.

Being generic, they are conservative, and there can be limitations on how they are used.

If a manufacturer's generic seismic design guide is used, the working sheets must be submitted with the PS3. Manufacturers' generic seismic design guides are the only proof of compliance when not an SED.



# 9

## Specific engineering design (SED)

Projects that are more complex than those that can be designed from the manufacturers' generic seismic design guides are classified as specific engineering design (SED).

Reasons why a project would be classified as SED include (but are not limited to):

- complexity of the ceiling
- size of the ceiling
- building importance level
- floor to ceiling height
- ceiling to structure (plenum) height
- other building components in the plenum
- design working life (annual probability of exceedance).

Manufacturers' design guides for lined plasterboard ceilings or bulkheads are becoming more available. Check manufacturers' or suppliers' websites for the most up-to-date information.

The designer will need to decide if an SED is required or whether manufacturers' generic design guides are appropriate.

A Chartered Professional Engineer (CPEng) must be engaged to carry out all specific engineering designs.

# 10

## Generic details

The following drawings show some generic details that can be used for seismic restraint and separation of ceilings.

Manufacturers will have their own proprietary systems that may have different ways of achieving the same outcome.

Seismic separation joints can be either large (usually greater than 20 mm) or small, and they can be visible or hidden within the ceiling system.

It is possible to use seismic joints in just one direction.

### SEISMIC SEPARATION JOINT DETAILS

Seismic separation joints can provide solutions when:

- back bracing may not be practical or achievable
- perimeter fixing is allowable but grid allowable length is less than the actual ceiling length.

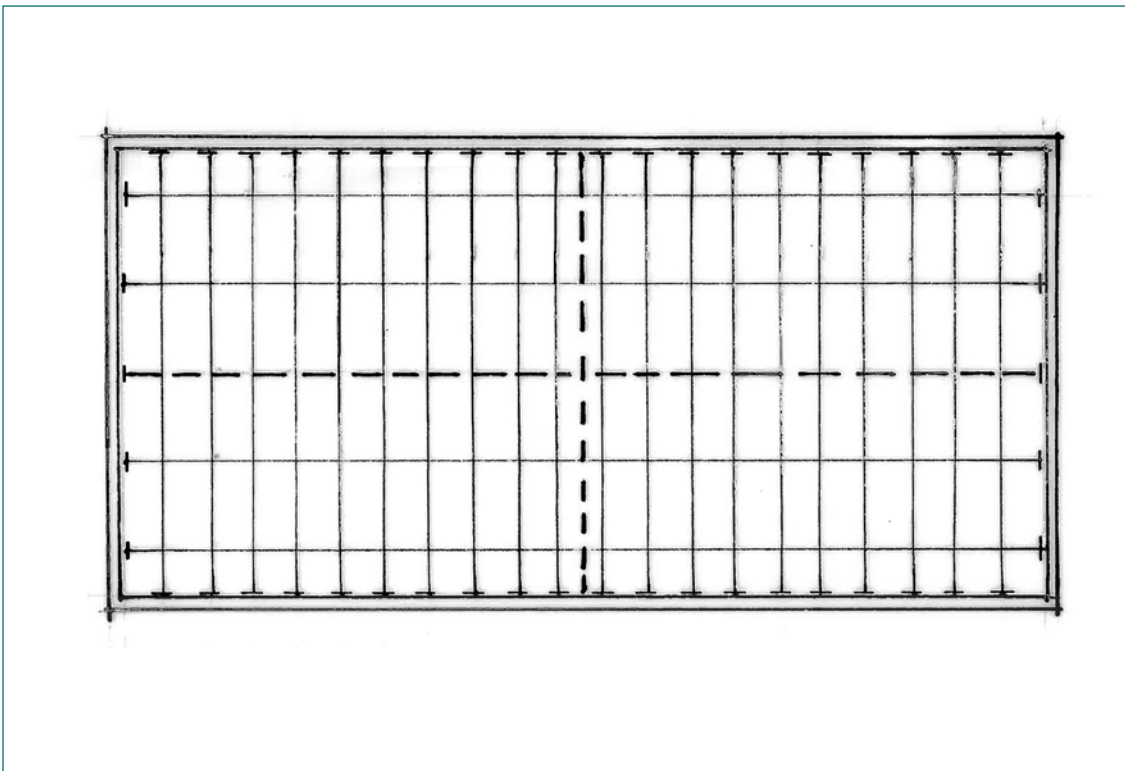

Figure 41: Seismic separation joints shown in both directions.

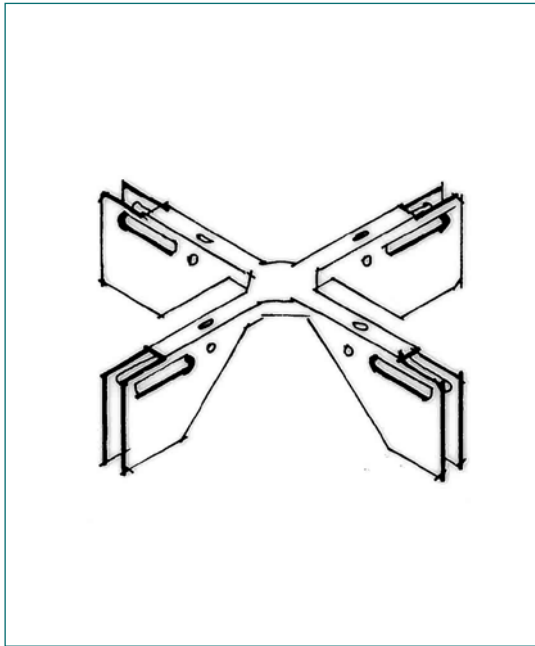

Figure 42: Small seismic joint, two directions, hidden joint.

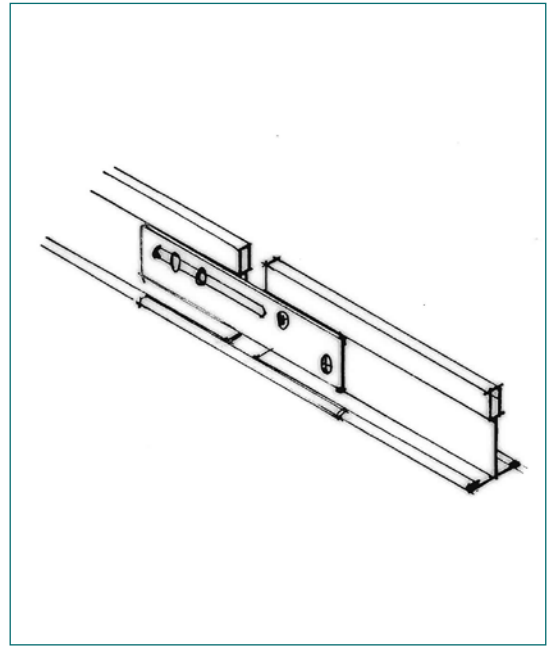

Figure 43: Small seismic joint, one direction, hidden joint.

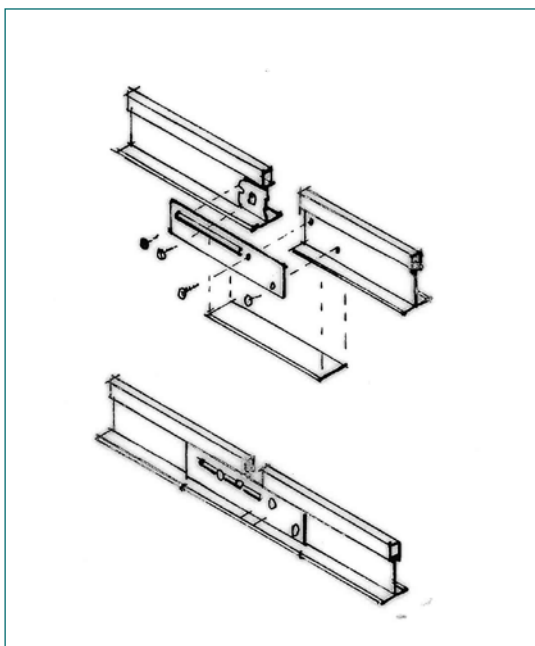

Figure 44: Seismic joint clip – main beam.

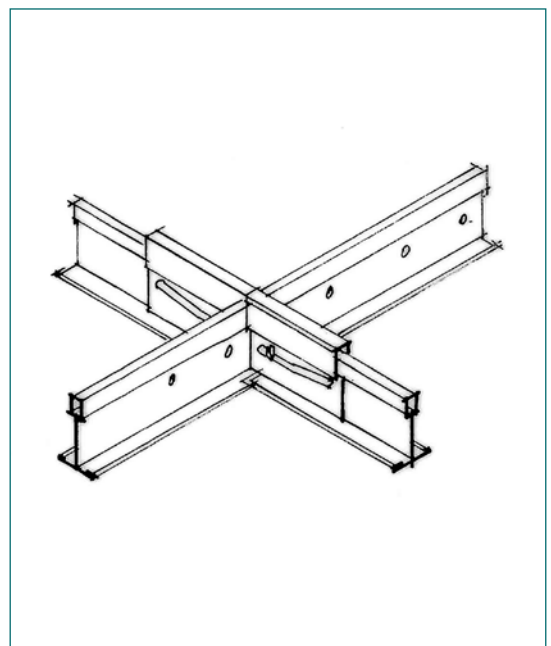

Figure 45: Seismic joint clip – cross tee.

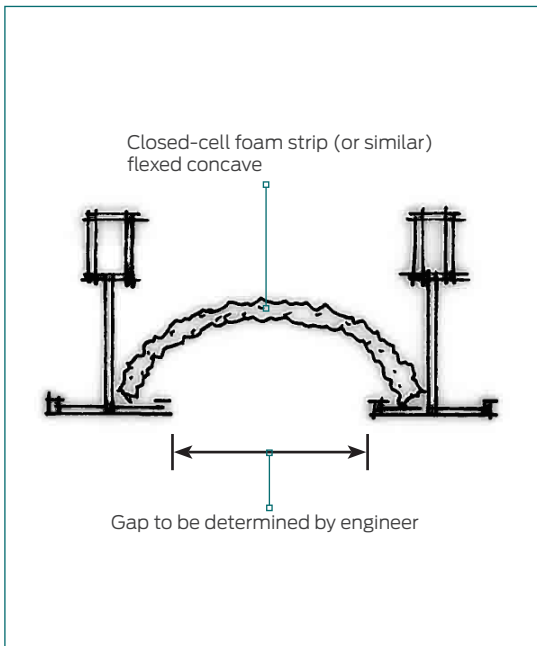

Figure 46: Large seismic joint with concave cover strip.

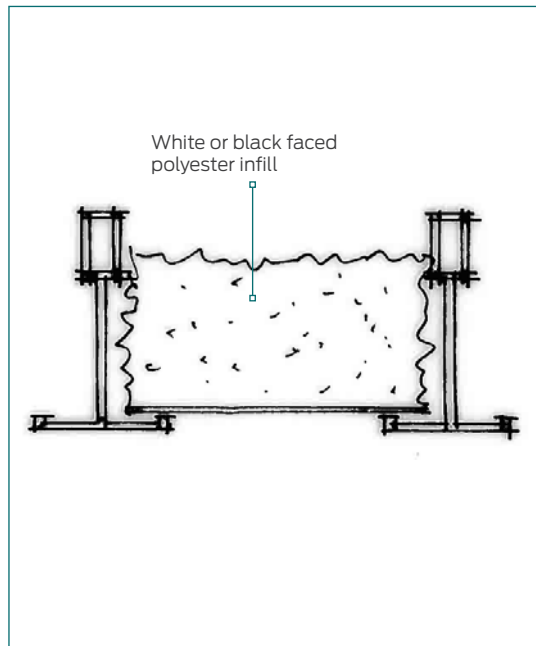

Figure 47: Large seismic joint with cover strip at bottom of T-rail.

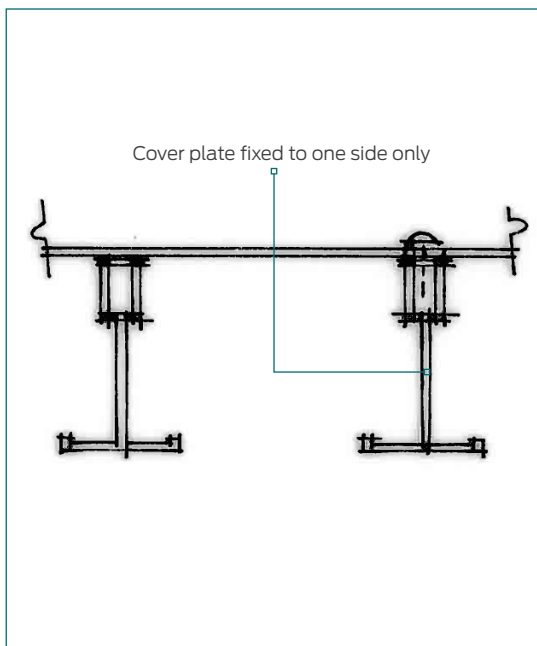

Figure 48: Large seismic joint with cover strip above T-rail.

## LATERAL FORCE BRACING

Lateral force bracing can be provided by perimeter restraint, K-bracing or use of vertical struts (compression posts) and supporting bracing for exposed grid systems.

Lateral force bracing shall be calculated from the manufacturers' generic design guides or subject to SED.

Seismic braces shall be attached to the grid and to the structure in such a manner that they can support a design load as calculated.

Support braces are to be within 50 mm of the connection of the vertical strut to the suspended ceiling.

Vertical struts must be positively attached to the suspension systems and the structure above. The vertical struts may be angles, metal studs or a proprietary compression post.

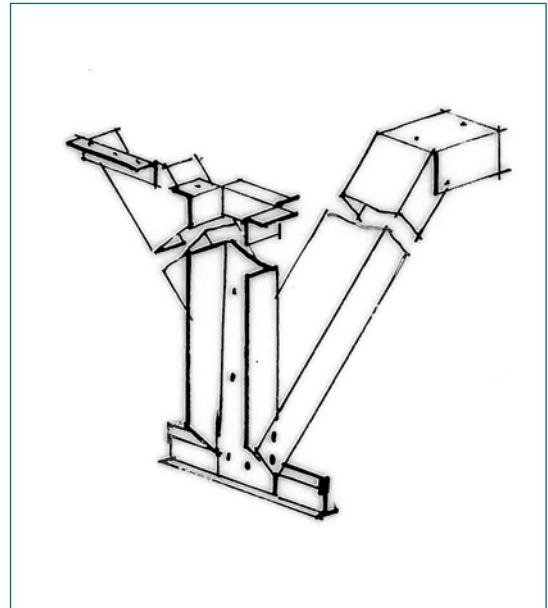

Figure 49: Lateral force bracing using solid struts.

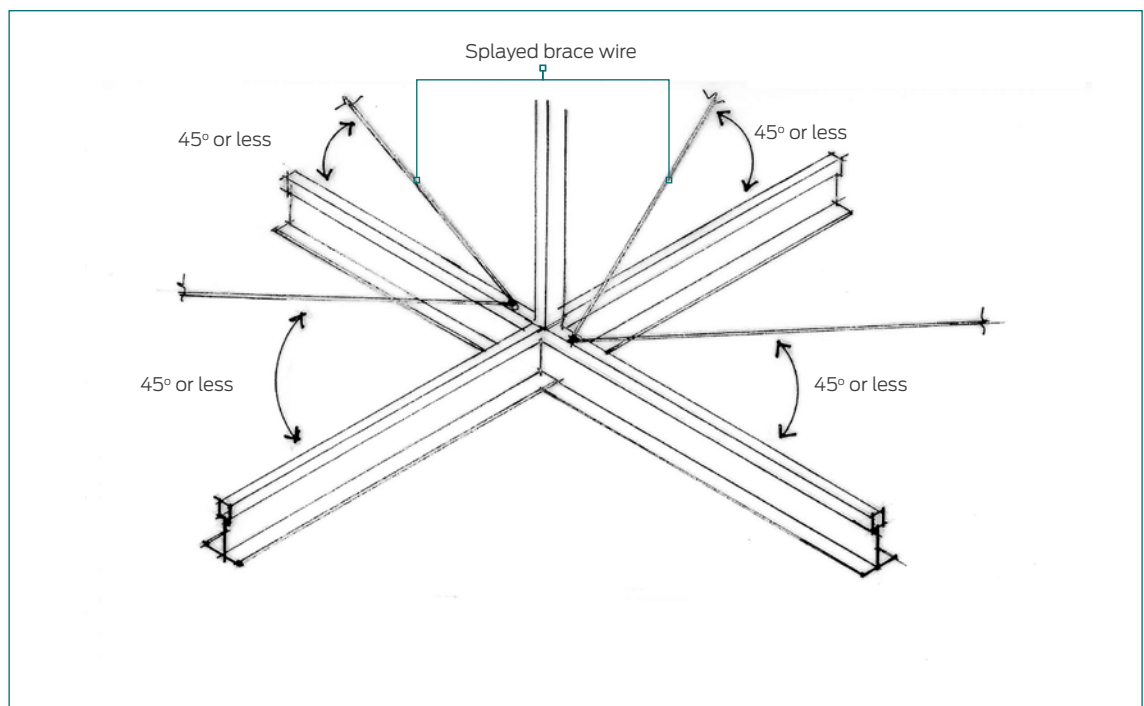

Figure 50: Lateral force bracing using splayed wires.

## PERIMETER RESTRAINT

Generally, one end of the ceiling grid shall be attached to the wall moulding or wall, and the other end shall have a clearance from the wall and be free to slide, with the required gap to be determined by the seismic design.

Attachment is typically with aluminium pop rivets or proprietary engineered components.

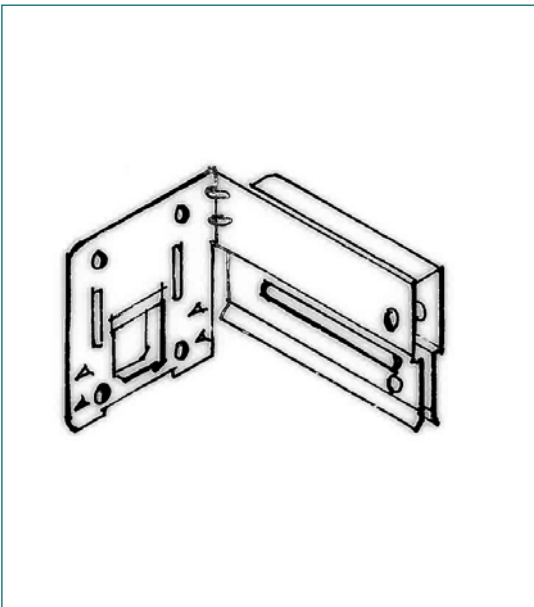

Figure 51: Proprietary wall clip.

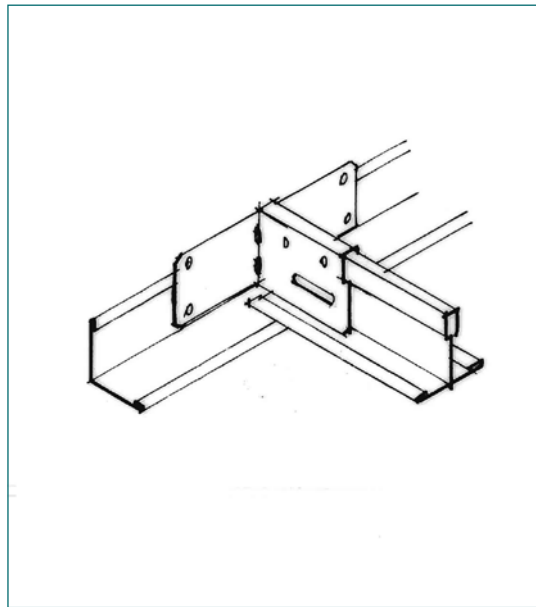

Figure 52: Proprietary wall clip in place.

### Fixed-end options

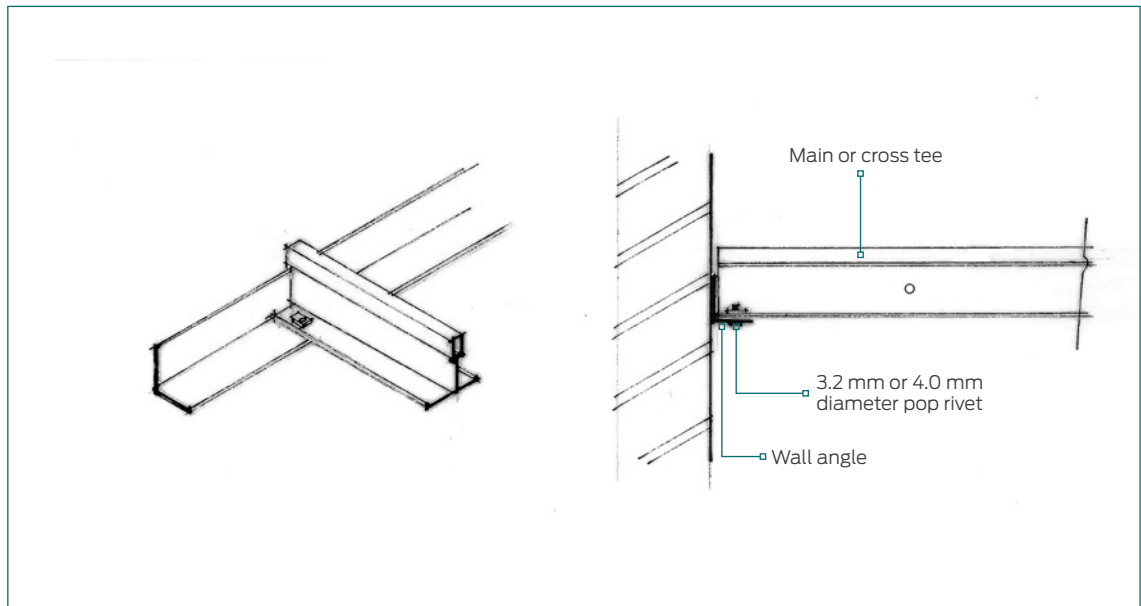

Figure 53: Pop rivet.

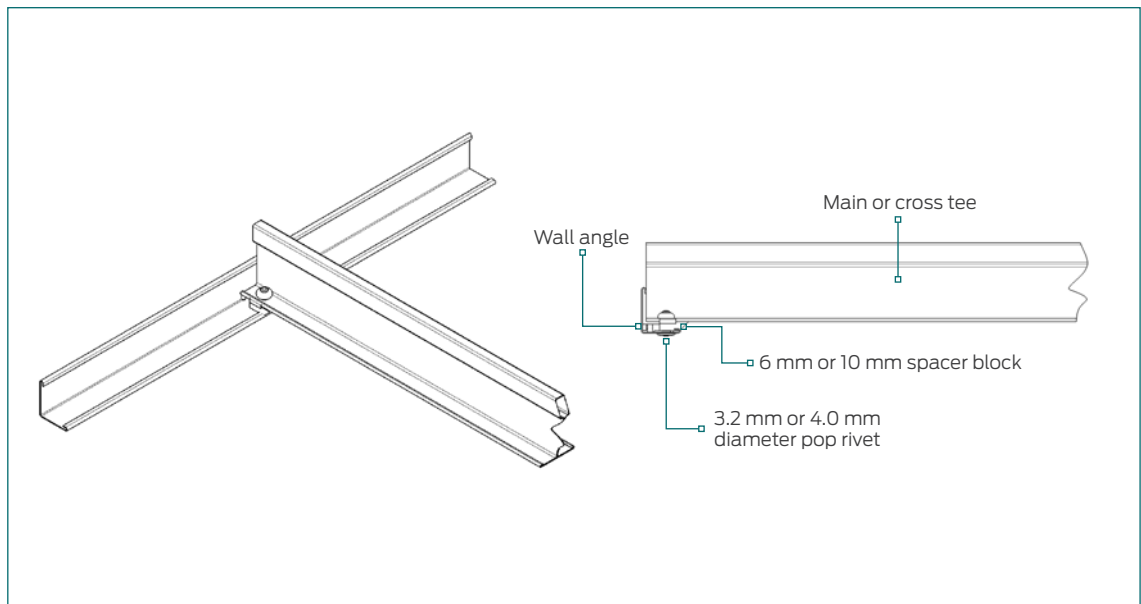

Figure 54: Pop rivet with spacer block (used with rebated tiles).

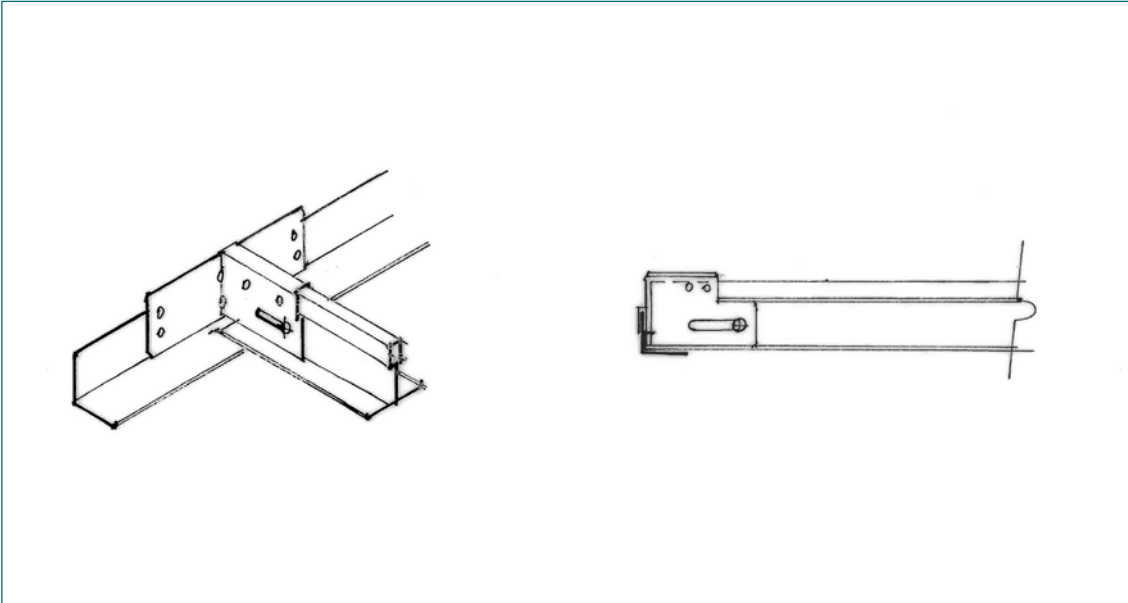

Figure 55: Seismic clip – main or cross tee.

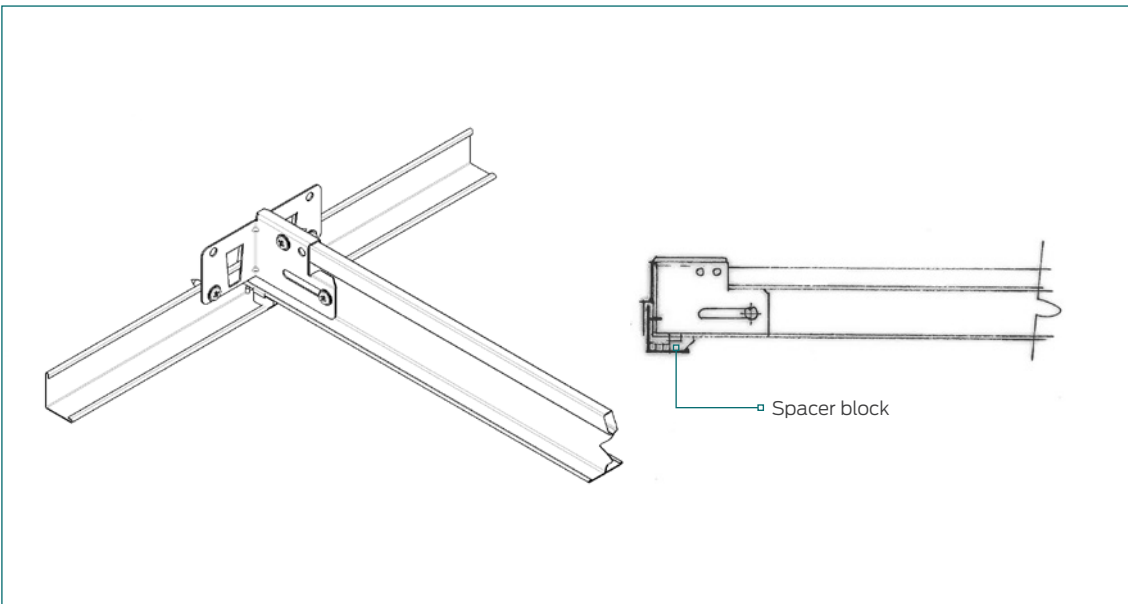

Figure 56: Seismic clip – cross tee with spacer block.



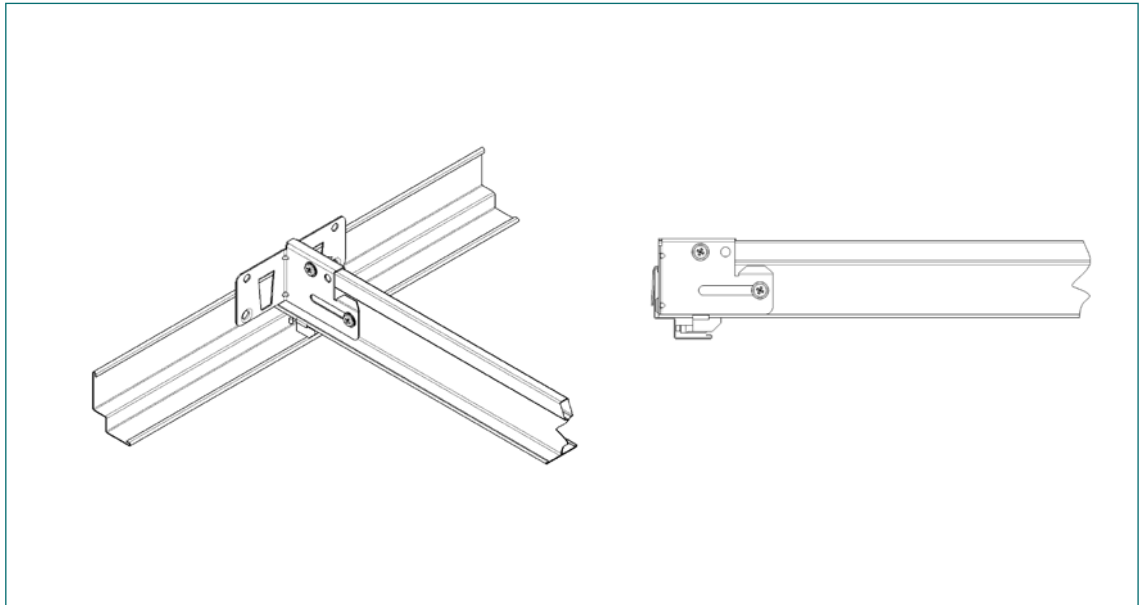

Figure 57: Seismic clip – main or cross tee with spacer block and shadow wall angle.

**Non-fixed-end options**

The grid shall be attached at two adjacent walls (pop rivets or other approved method).

There must be solid blocking in the wall or a solid wall capable of taking the lateral force of the ceiling.

The two other adjacent sides left to move freely shall be restrained sufficiently to not allow the grid or tiles to collapse, typically achieved with a channel wall moulding, proprietary components or specific design.

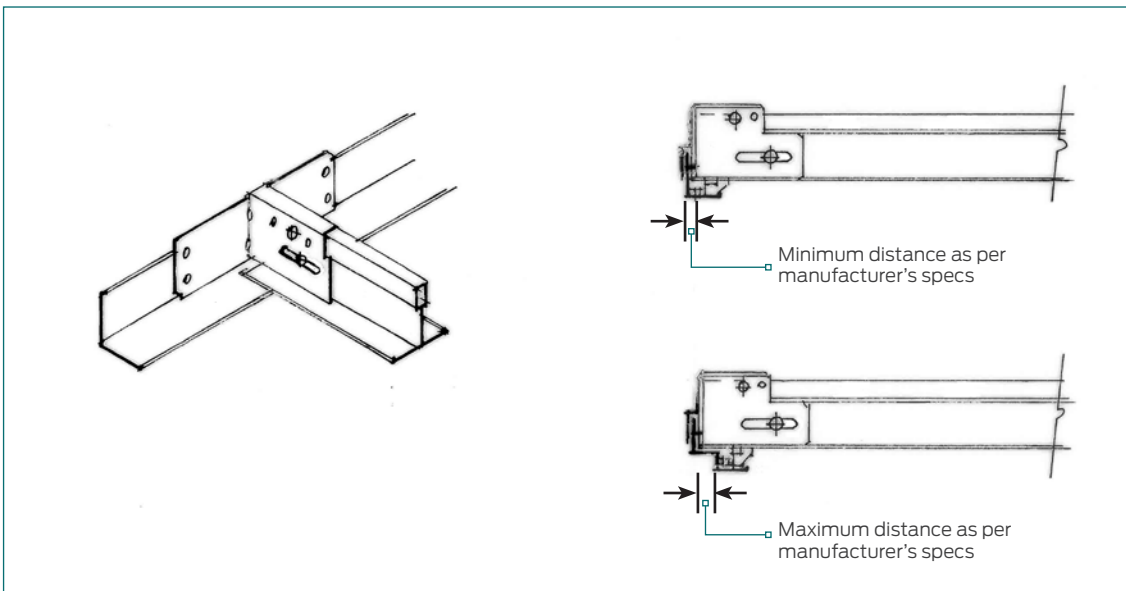

Figure 58: Seismic clip – wall angle and wall angle with spacer block.

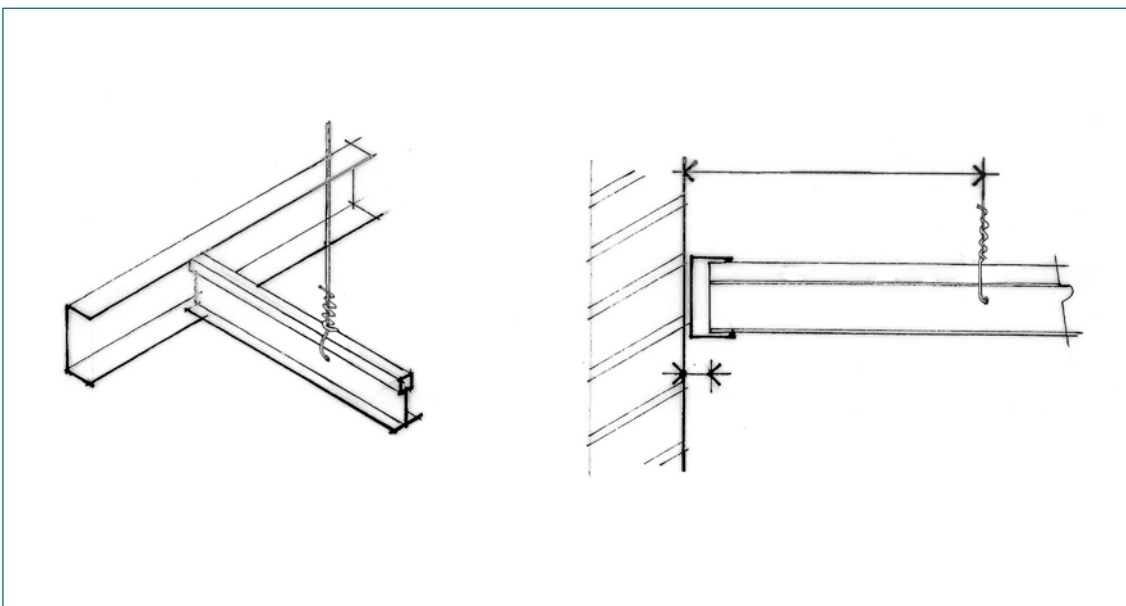

Figure 59: Seismic channel.

## TILE CLIPS

Tile clips can help retain tiles in a ceiling against vertical movement in a seismic event, wind pressure and if required under specific engineering design (SED).

Refer to manufacturers' recommendations.

## HANGERS

The requirements for hangers are as follows:

- Hanger and perimeter wires must be plumb within 1 in 6 unless counter-sloping wires are provided.
- Suspension hangers shall be spaced at 1200 mm centres maximum or as specified for the loading.
- Shot-fired fasteners into concrete are to be approved for the individual site.
- When using concrete anchors, they shall be installed in accordance with the manufacturer's recommendations, taking due care to maintain minimum edge distances, spacing and embedment depth in accordance with NZS 3101:2006 *Concrete structures standard* clauses 17.5.5 and 17.6.
- Cast-in anchors often present alignment problems for suspended ceilings.
- Fixings into aerated concrete or lightweight concrete requires special attention and shall only be made in accordance with the manufacturer's recommendations.
- Refer to specific values in AS/NZS 2785:2000 clause 3.2.2 (c) of 50 kg plus factors to allow for variability in Table 6.2.2 in AS/NZS 4600:2005.

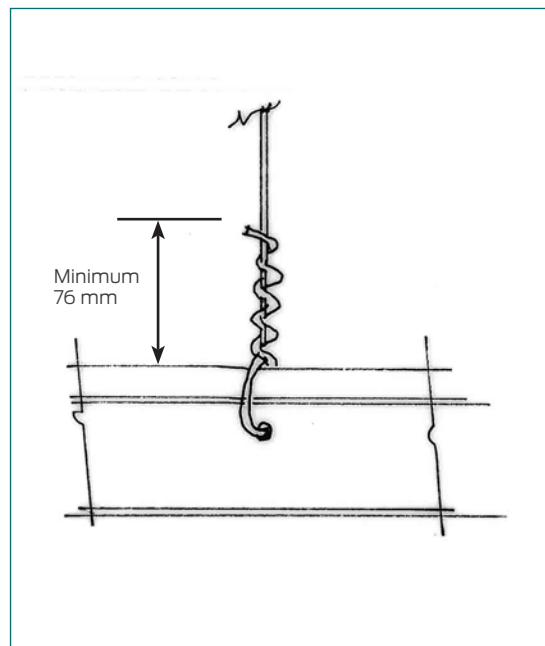

Figure 60: Hanger wire minimum tie-off.

- Wires shall not attach to or bend around interfering material or equipment. A bridging system or similar device shall be used where obstructions preclude direct suspension. The bridge type and suspensions shall be engineered for the spans as required. Refer to AS/NZS 4219:2009 Table 15.
- All wire ties are to be three tight turns around itself within 75 mm (see Figure 60), 2.5 mm diameter hanger wire spaced 1200 mm on centre maximum.

## BRIDGING

Bridging is required when hanger points cannot be accessed because of obstruction by services.

Best practice is to co-ordinate services to allow access to hanger points.

The two details shown in Figure 61 are a guide for ceiling supports around and next to services. Services are required to comply with NZS 4219:2009, which specifies seismic clearances between adjacent building services components as well as between building services components and other non-structural components, for example, including ceilings.

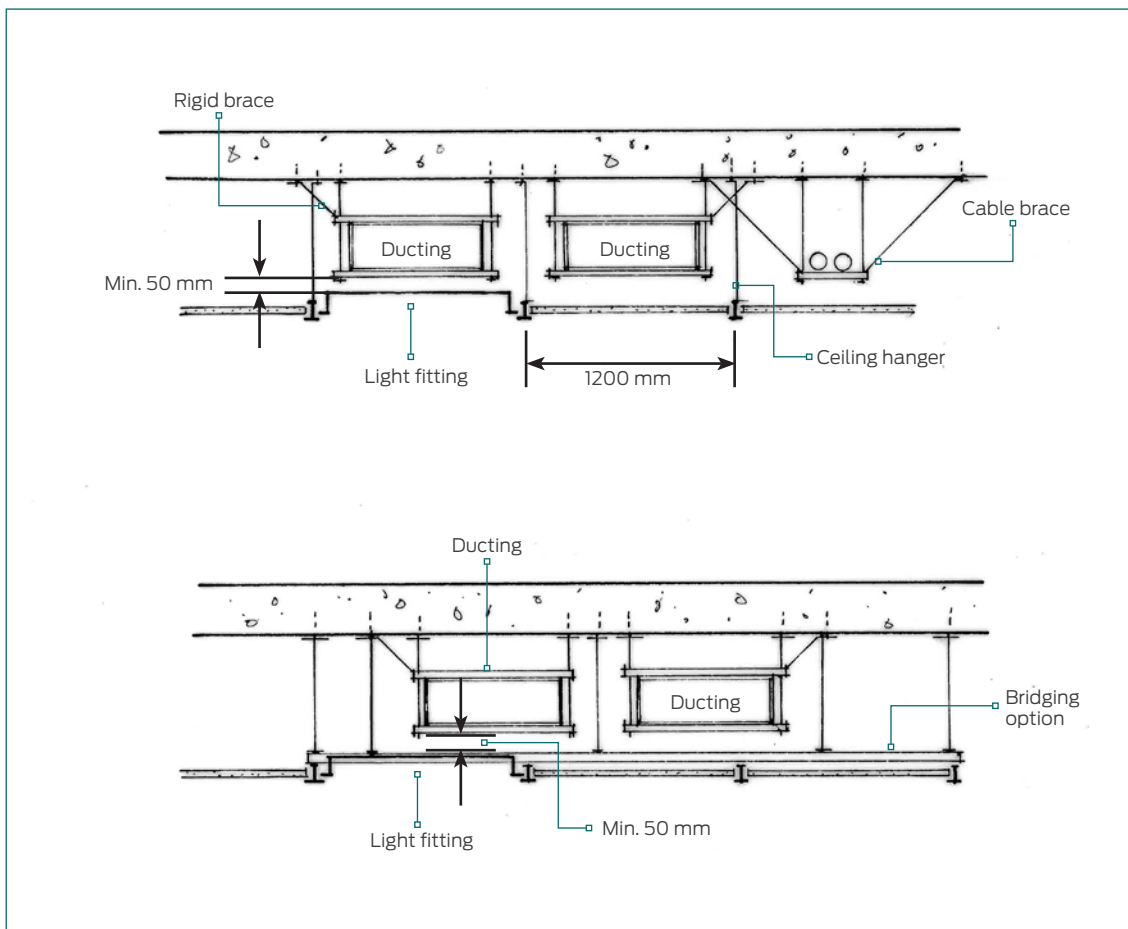

Figure 61: Bridging under ducts or services by other trades.

## TRAPEZE

An opposing angle wire suspension system can be used where hanger points cannot be used because of obstruction by services.

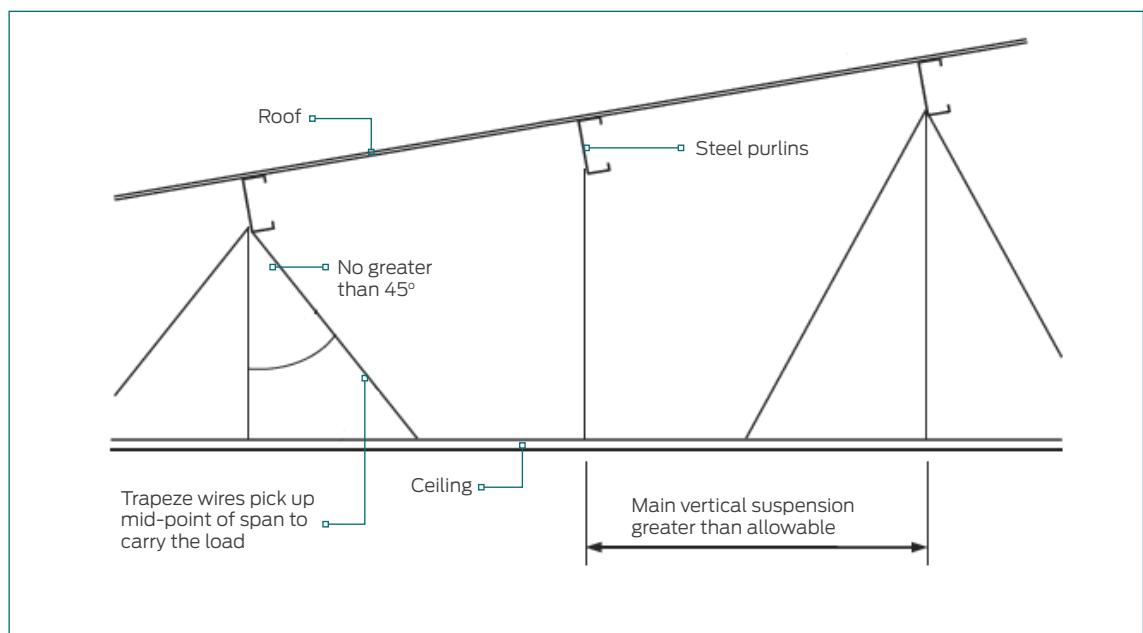

Figure 62: Typical trapeze.

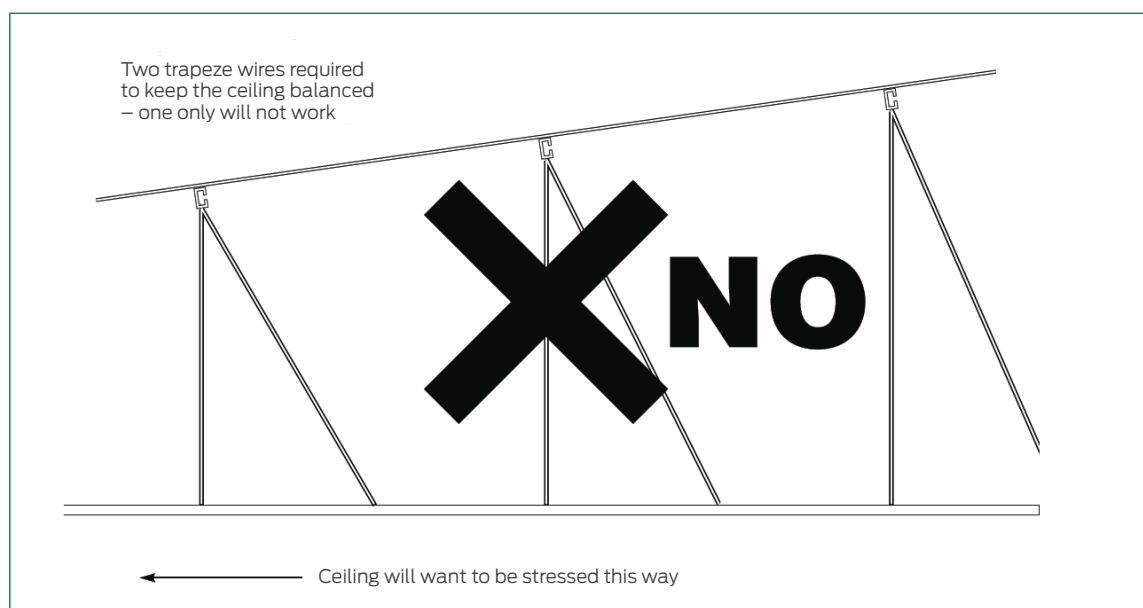

Figure 63: Trapeze wire detail.

# 11

## Possible reasons for and consequences of failure

There are many reasons for possible failure of the suspended ceiling, including but not limited to:

- unsuitable ceiling design
- the use of an unsuitable product/system
- installation not meeting the requirements of either the manufacturer, supplier or the NZBC
- ceiling wires not installed correctly
- services within the ceiling space or connected to the ceiling grid not complying with current codes
- perimeter hangers or bulkheads having insufficient strength to receive the line loads of a ceiling
- insufficient seismic gaps to allow for movement of the building structure or other non-structural elements
- partitions being connected to the ceiling system but not independently braced
- a lighter gauge of ceiling grid or non-tested system being installed outside its structural capability
- interference from other non-structural building components in the plenum.



Figure 64: Lack of suspension points and service clearance.



Figure 65: Unbraced partitions and service ducts.



Figure 66: Sprinkler system supported from ceiling componentry rather than suspended from the building structure.



Figure 67: The result of an unbraced ceiling.

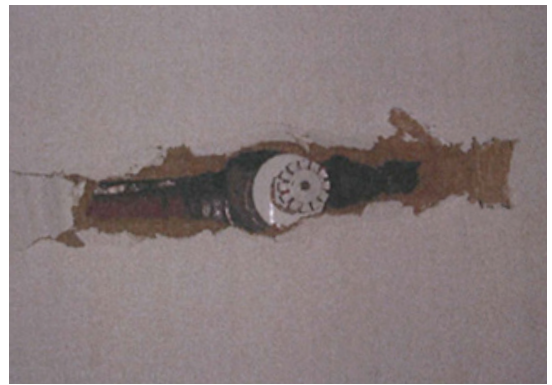

Figure 68: Damage to ceiling tile from an unrestrained fire protection system.



Figure 69: Damage caused by unrestrained services.



Figure 70: Lack of suspension points.



# 12

## Tendering

Suspended ceiling contractors tendering for suspended ceilings must consider and make due allowance for the cost implications of the seismic restraints and seismic design that will be required and clearly identify the provisions that have been made.

### OPTIONS FOR TENDERING

The need for ceilings to be seismically resistant is not new. However, there is a new awareness of the need to be able to demonstrate that installed ceilings have been properly seismically restrained.

A suspended ceiling contractor shall check at the time of tendering the actual requirements for each ceiling, having regard to its designated AWCi seismic grade and the requirements of the tender documents. The tender documents should include structural engineering information required for tender options 2 and 3, including annual probability of exceedance, building importance level, building component category, SLS/ULS, provisions for load transfer to structure, requirements for producer statement and any confirmation that services loads will be restrained in accordance with NZS 4219:2009.

In the interests of ensuring true competition in the marketplace, each company must determine its own commercial terms, including but not limited to the prices charged, the risks accepted and the wording of its tenders. Therefore, any AWCINZ recommendations regarding tendering methodologies are advisory only and are intended to raise awareness of the issues that should be considered in determining a tender price. Suspended ceiling contractors should also be mindful that qualified (or tagged) tenders may be treated as non-compliant and may not be considered. The options developed by AWCINZ in its tendering protocol are designed to assist tenderers to:

- submit offers based on consistent information
- reduce the number of tags
- reduce the number of on-site variations
- reduce the number of on-site work conflicts with other trades
- give a more accurate costing
- reduce the number of variables in the tender.

There are three main options for responding to tenders. The response will depend on the level of information available at the time of tender.

### OPTION 1: WHERE TENDER DOCUMENTS INCLUDE FULL DETAILS OF SEISMIC RESTRAINTS

This option is preferred to encourage fully conforming and untagged tenders and to assure fully compliant ceiling installations. Prepare the tender to include the following qualifications.

#### **Model tender qualification where seismic restraints are fully detailed**

We have allowed for the seismic restraints as detailed on the understanding that they have been fully designed and detailed in the tender documents to conform with the requirements of AS/NZS 2785:2000 and NZS 1170.5:2004. The suspended ceiling contractor will be responsible only for the installation of the restraints as detailed and for the provision of the associated construction producer statement (PS3) to confirm that the ceiling has been constructed in accordance with the design.

Any additional bracing or modification to the ceiling system to achieve the required level of seismic bracing or to co-ordinate with structural elements or building services shall be a variation.

We have not allowed for any engineering design, design producer statements (PS1, PS2), installation review by engineer (PS4) or for any additional work that may be required to co-ordinate the ceiling supports and restraints with



other services and their associated restraint systems and spatial requirements.

### **OPTION 2: WHERE SEISMIC RESTRAINT DESIGN IS REQUIRED TO BE CARRIED OUT AT CONSTRUCTION STAGE**

Unless seismic restraints have been fully designed and detailed in tender documents, it is unlikely that the documents supplied to the suspended ceiling contractor will have enough information to determine the seismic restraints requirements and their interface with the structural elements and building services.

As the nature and cost of seismic details will not be known until completion of design by the seismic specialist, this methodology will require the inclusion of provisional sum allowances in tenders for seismic restraints.

Ideally, the provisional sum allowances, based on the nominated seismic grade and any additional bracing requirements over and above the minimum required to comply with the NZBC will be specified in tender documents. Where this is not done, the suspended ceiling contractor should nominate a provisional sum allowance in the tender and include that allowance in its tender price.

This option encourages fully conforming tenders generally limited to category P7 (NZS 1170.5:2004 Table 8.1) ceilings to serviceability limit state (SLS1) (with limited ULS options also available). Option 2 tenders should identify the proposed bracing concept, the applicable manufacturer's generic design guide and any underlying design assumptions.<sup>6</sup> Any ceilings outside the scope of manufacturers' generic design guides should be nominated in the tender and identified for specific engineering design and a provisional sum allowed for engineer-designed bracing as option 3.

### **Model tender qualification where seismic restraints are not detailed in tender documents**

We have allowed for ceilings to be constructed to the following seismic grades in accordance with the AWCINZ *Code of Practice for Design, Installation and Seismic Restraint of Suspended Ceilings*:

- Ceiling [identify] – seismic grade AWCI SG[number]
- Ceiling [identify] – seismic grade AWCI SG[number]

As the seismic restraints have not been fully designed, we have allowed a provisional sum of \$[state amount included in tender price].

[OR, where a provisional sum is nominated in the tender documents]

We have allowed the specified provisional sum of \$[state amount included in tender price].

The provisional sum shall cover all costs associated with specialist engineering design and issue of associated design producer statements (PS1), any design review statement (PS2), the supply and installation of seismic bracing and engineering monitoring and provision of engineer producer statements (PS4) that may be required for the actual seismic restraints.

### **OPTION 3: SPECIFIC ENGINEERING DESIGN**

Specific engineering design is required where option 1 does not apply and option 2 does not apply to some or all ceilings.

Unless full engineering data has been provided within the tender documents, such design must be carried out post-tender when full structural

and building performance data is available. Where the scope of seismic bracing cannot be accurately ascertained at tender, a provisional sum<sup>7</sup> should be nominated for the added cost of bracing.

### **Model tender qualification where specific engineering design is required**

We have allowed for ceilings to be constructed to the following seismic grades in accordance with the specific engineering design supplied.

The main contractor shall, without charge to the ceiling contractor:

- provide suitable fixing points and all secondary steelwork, purlin blockings and so on for fixing of ceiling hangers and bracing
- provide continuous nogs to allow solid fixings wherever ceilings abut partitions and bulkheads
- ensure that all in-ceiling services are installed strictly in accordance with NZS 4219:2009 including that all components and services over 10 kg are restrained from gravity and earthquake forces with proper clearances from ceiling and supports in accordance with NZS 4219:2009
- co-ordinate the required bracing with structure and in-ceiling services.

Any requirement for additional steelwork to modify proposed bracing or support requirements due to a lack of structural fixings and support or for co-ordination with in-ceiling services is a variation.

## **GENERAL TENDER QUALIFICATIONS**

- Producer statements, where specified, shall be provided for the entire design and/or the completed ceiling installation. Any additional or interim producer statements for separate areas or completion stages shall be a variation.
- Drawings shall comprise as a minimum reflected ceiling plans marked up to show the position and type of seismic bracing and seismic control provisions.
- Drawings submitted for approval shall, unless approved in writing, be deemed approved within 10 working days of submittal.

## **TENDER, CONSENT AND SHOP DRAWINGS**

Several types of drawings can be produced for a project. The contract type will determine what will be produced and by whom:

- Tender documents can give performance requirements for the suspended ceiling or can

be more detailed, depending on the nature of the design methodology. They must contain at least some minimum physical information as well as the finished aesthetic. Usually produced by the lead designer.

- Consent drawings must show how the proposed system meets the requirements of the NZBC and the relevant clauses (B1 *Structure* and B2 *Durability*). Usually produced by the lead designer.
- Shop drawings show every nut, bolt or washer so that all components can be priced accurately. Produced by the installing company.

Shop drawings define the seismic restraint types and locations, engineering calculations, inspections for construction monitoring and certification. The development of shop drawings for seismic restraints requires:

- co-ordination of the designer's reflected ceiling plans with structural and architectural features and partitions
- co-ordination of ceilings with building services installed within the ceiling void attached to or suspended above or adjacent to the ceiling and other architectural features
- co-ordination of ceiling and above-ceiling services restraints and seismic clearances
- providing support and bracing of building services and other components over 10 kg supported by the ceiling system.

This may require attendance on co-ordination meetings and discussions with relevant services and partitioning trades as early as practicable to establish methodologies for key co-ordination issues.

Design details and appropriate producer statements may be required in the consent application and project specification.

<sup>6</sup> Unless otherwise stated in the ceiling contractor's tender, underlying assumptions include building importance level of 3 or less (AS/NZS 1170.0:2002 Table 3.2), relevant geographic location (NZS 1170.5:2004 Table 3.3), annual probability of exceedance 1/25 (AS/NZS 1170.0:2002 Table 3.3) and adequate space and fixing provisions for installation of compliant seismic restraints. The main contractor or the client's structural engineer should verify tenderers' stated assumptions post-tender when full engineering data is available and any required additional bracing should be a variation.

<sup>7</sup> A provisional sum (not being an estimate) for seismic bracing should identify the ceiling areas requiring specific engineering design to cover the cost of specialist engineering design, design producer statements (PS1), supply and installation of seismic bracing and engineer producer statements (PS4) for the actual seismic restraints. Unless otherwise stated, such provisional sum would be additional to the tender price.

# 13

## Installation

### SITE INSPECTION

Internal ceiling installation work is not to commence until the building is effectively watertight and the work of all wet trades has been completed and dried, unless specifically designed for this situation.

External ceiling work can commence once the construction above the ceiling is completed.

### MATERIAL STORAGE AND HANDLING

Ceiling tile faces are the visible finished face, so ensure hands are clean and grease-free when handling the tiles.

When materials are stored on site, they must be laid flat and protected from water or impact damage.

### PRE-INSTALLATION CHECKLIST

Before commencing work, the installer needs to confirm with the project manager the installation parameters:

- Where will materials be stored? Is it safe and secure? Is it clean? Will the materials sustain any damage?
- Will the installer have clear access to do their work, or will other trades be working in the same space at the same time?
- Will the installer be able to complete their work in one continuous time period with no interference from other trades, i.e. can they safely leave work incomplete or must they secure it at the end of each day?
- Will the installer be able to complete their work on consecutive days?
- Will scaffolding/elevating work platforms be available for the installer's use, or do they need to provide their own?
- Will lighting and power be supplied?
- Who is responsible for clearing waste materials, and where are these to be deposited?
- Will the space be fully closed in and protected from external weather before installation commences?

- Has the set-out point for all subtrades in the plenum been determined?

### FACILITIES FOR INSTALLATION OF SUSPENDED CEILINGS

Unless otherwise agreed, a suspended ceiling contractor is entitled to assume that a builder/client will provide the following upon request and free of charge:

- Suitable fixing points and adequate space for the gravity hangers and seismic restraints for the suspended ceiling system.
- All secondary steelwork, framing, purlin blockings and the like in suitable positions to attach ceiling hangers and braces.
- Continuous nogs to provide for solid fixing to partitions and bulkheads where ceilings abut.
- All partitions appropriately braced independent of the ceiling grid by the partition installer to avoid lateral force on the ceiling grid.
- All in-ceiling services installed strictly in accordance with NZS 4219:2009.
- All components and services over 10 kg to be supported by the ceiling system shall be restrained by the relevant installer from gravity and earthquake forces, and producer statements shall be provided.
- Installers of components and services will certify the actual weight of any services under 10 kg that are to be supported by the ceiling grid.
- Building services installed with proper clearances from ceiling and supports in accordance with NZS 4219:2009.
- In-ceiling services designed with due allowance for the gravity supports and seismic bracing that will be required.

Any requirement to provide additional steelwork or to modify the planned bracing or support requirements due to a lack of reasonable provision for gravity fixings and support for the ceiling and associated bracing, or to overcome clashes with in-ceiling services, will be treated as a variation.

## BEST-PRACTICE CO-ORDINATION WITH OTHER CEILING SERVICES

The installer should view all drawings relating to the plenum before commencing installation work. They need to be aware of other trade work to be installed in the void, wall/ceiling junctions, movement joints, seismic restraints or lack thereof.

A meeting should be held with the project manager and all other trades to ensure that access, timing, conflicts and so on of all work in the plenum is co-ordinated. Any conflicts that arise must be brought to the attention of the project manager and resolved before any further work is installed. It is the responsibility of the installer to visually inspect all aspects of the project before commencing. If there are any issues arising, they should be resolved fully via the project manager before commencing any work.

## INSTALLATION DETAILS TO SEISMIC DESIGN

The designer or engineer is responsible for a complying workable design. However, the installer must not carry out any installation if it is immediately obvious that there is either a conflict with another building component or there is a deficiency in the design. If such a situation arises, the installer must resolve this with the engineer and project manager before proceeding any further.

## AESTHETICS

There are many design details that can influence the finished aesthetic of a ceiling design, both from a design and a good workmanship perspective. These include:

- construction tolerances
- consistent shadow gaps
- accurate 90 degree angles
- wall angle alignment
- large wall angles ( >25 mm ) often show waves
- level = 1 in 360 maximum.

Installers must be trained either by the supplier and/or their installation company on the appropriate health and safety issues.

## SPECIALTY TOOLS

Installers must be trained either by the supplier and/or their installation company on how to deal with the proprietary fittings for different types of systems, but the minimum range of tools that they must know how to use are:

- laser levelling systems
- aviation snips
- pop rivet gun
- hole punch
- hole saw
- screws
- grid clips.

## QUALITY ASSURANCE

The two key principles of quality assurance (QA) are that products are:

- fit for purpose – the product is suitable for the intended purpose
- right first time – foreseeable mistakes are to be eliminated.

Though outside the scope of this Code of Practice, QA includes management of the quality of raw materials, assemblies, products and components, services related to production as well as management, production and inspection processes.

Site variations can be minimised by carrying out some pre-installation processes such as:

- checking that the correct product and the correct volume has arrived
- co-ordinating installation processes with other trades to remove any conflicts
- reviewing installation drawings for layout and fixings of all other building components in the plenum.

Any quality control programme shall include:

- inspection of material and workmanship
- conformance to plans/construction documents
- special inspections
- a thorough inspection throughout and on completion of the project.

Hand-over sheets shall be signed by all parties involved to show that the installation has been

completed as designed and specified (see Appendix E for a sample QA sheet).

## INSPECTION

An inspection of ceiling framing prior to installation of tiles or panels shall include checking for compliance with the manufacturer's recommendations and in particular:

- spacing of support hangers – typically 1200 mm maximum but reduced around the perimeter to 400–600 mm typically
- angle of hanger support – no more than 1 in 6 from vertical
- fixing of support hangers – screwed to purlin webs, never hooked over purlin lips, never pop riveted, never shot-fired fixings
- perimeter fixing – perimeter brackets fixed where necessary
- adequate support of ceilings beneath large service ducts or group of closely spaced services (bridging members may be needed), and the ceiling system shall not be suspended from any building services such as ducts
- support around access hatches – ensure support members are not cut unless additional trimmers and hangers are provided, note manufacturers' recommendations around additional trimmers to support openings and ensure the opening will not adversely affect the ceiling's performance in an earthquake
- support of lighting – ensure lighting is fixed into or supported independently as per the intended design, and note the manufacturer's recommendations around additional trimmers and/or hangers to support lighting
- downlights or other services shall not rely on the ceiling panel for support – they shall be installed in rigid infill, for example, MDF board, supported on the ceiling grid, or the load shall be transferred back to the ceiling structural components
- bulkheads shall be attached to the structural soffit, independent of the ceiling, unless specifically designed otherwise
- wind uplift – provide back bracing of ceilings to all external areas and where necessary to internal installations.

Seismic-specific detail check to include:

- seismic brackets to two adjacent walls and sliding joint to the other two walls where specified – ensure screws are fixed in the correct locations in the brackets, as in some systems, the screw location is the principal difference between a sliding and fixed connection
- back bracing is located as specified and constructed to the specific bracing details
- seismic joint clips are installed on main beam connections where recommended by the manufacturer or ceiling seismic designer
- seismic joint clips are installed on cross tee connections where recommended by the manufacturer or ceiling seismic designer.

## REFURBISHMENT WORK

For any refurbishment project, work must not commence before the primary support structure has been inspected and verified by a suitably qualified person as being structurally sound for a suspended ceiling to be hung from and/or attached to walls. An inspection should also include any other non-structural building components already in the proposed plenum or any new such components to be installed at the same time.

When extending, modifying or refurbishing existing ceilings, if available, the same components as existing shall be used to ensure a consistent finish.

Note that subsequent changes in the compliance requirements of the NZBC may require more extensive work to be carried out than a replacement of comparable component or assembly, for instance, there may have been an increase in the seismic capability required.

# 14

## Partitions

Partitions that are tied to the ceiling shall be laterally braced to the building structure. The bracing shall be independent of any ceiling splay bracing system, and the ceiling must not be perimeter fixed.

project-specific seismic gaps must be allowed for through any penetrations in the ceiling.

Here are some examples of partitions that are supported independently of ceilings.

Partitions are not to be braced to the ceiling unless they have been designed to do so, and

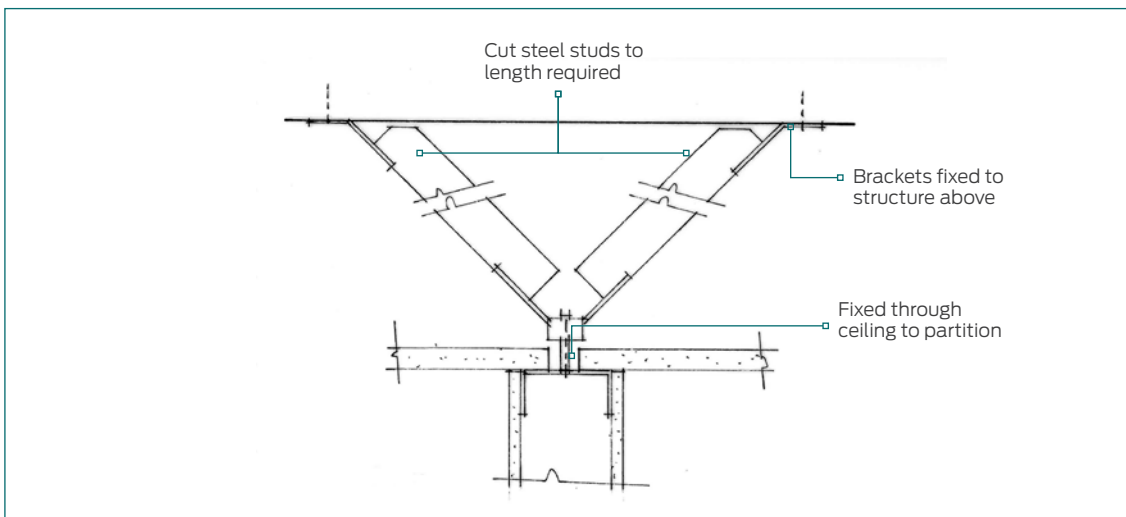

Figure 71: Proprietary internal wall bracing connection (isolated from ceiling movement).

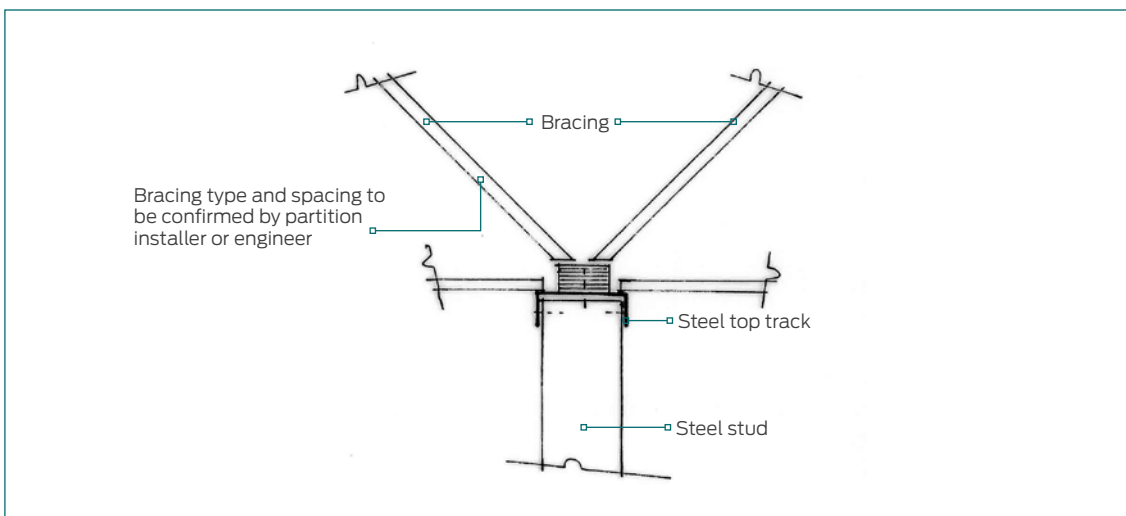

Figure 72: Generic internal wall bracing connection – wall terminates at ceiling.

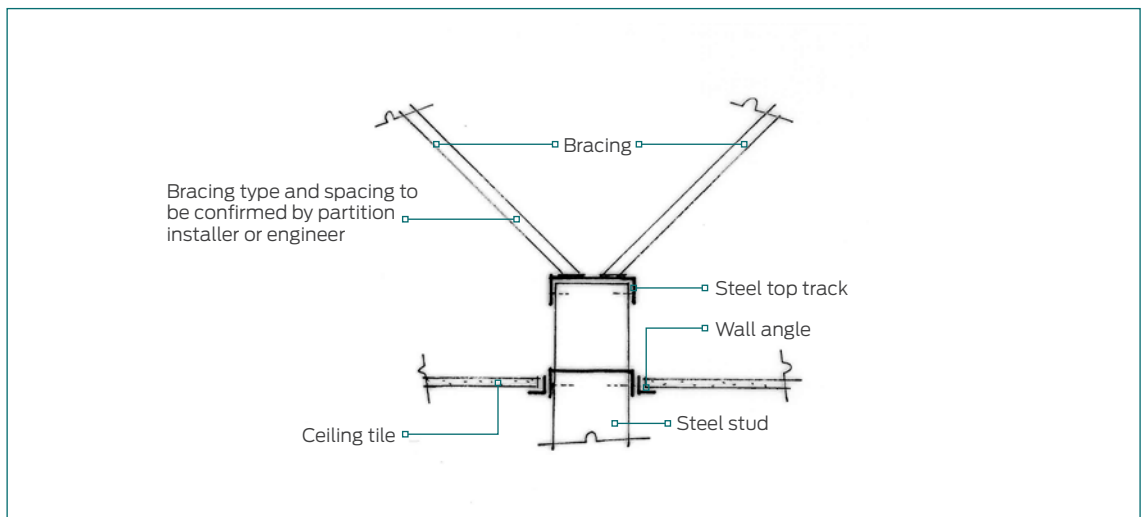

Figure 73: Generic internal wall bracing connection – wall terminates above ceiling.



Figure 74: Horizontal bracing.

# 15

## Fire and suspended ceilings

The fire design of suspended ceilings is outside the scope of this Code of Practice. The following information is intended to highlight some features of fire-rated ceilings.

Fire-rated ceilings may require specific engineering design for seismic restraint.

A fire-rated ceiling helps prevent fire and/or heat from reaching a floor or roof above a room that is on fire. This allows time for evacuation of the floors above and protects against property damage.

A fire-rated ceiling system is part of a total fire-rated assembly, which includes approved beams, joists and floor or roof assemblies.

The fire resistance rating of a building assembly (walls, floor/ceilings and so on) refers to the period of time the assembly will serve as a barrier to the spread of a fully developed blaze. It also refers to how long the assembly can function structurally after it is exposed to a fire of standard intensity as defined in AS 1530.4:2014.

The designation for a system to resist the passage of fire is represented by three performance measurements and normally expressed as 60/60/60, 30/30/30 and so on.

The numbers indicate minutes, which, in order of expression, represent:

- structural adequacy – failure occurs when the specimen collapses under load
- integrity – failure occurs when the specimen develops cracks or openings through which flames or hot gases can pass
- insulation – failure occurs when the average temperature of the unexposed surface of the specimen increases by more than 140°C above the initial temperature or the temperature at any point of the unexposed surface increases by more than 180°C above the initial temperature.

### PASSIVE FIRE

Penetrations through fire-rated ceilings need to be protected to the same rating as the ceiling and adequately restrained so that, in the event of seismic movement, the fire rating is not compromised.

This is dictated by the specification and can be determined by a fire engineer or manufacturers' product literature as to the type of treatment required.

The individual who penetrates the passive fire protection is responsible for ensuring that the integrity of the passive fire protection is maintained and/or reinstated after work is completed.



# 16 Acoustics

The acoustic design of suspended ceilings is outside the scope of this Code of Practice. The following information is intended to highlight some features of acoustic-rated ceilings.

Acoustic ceiling systems are designed to deal with sound 'pollution' – unwanted sound either from noise within the room or from noise travelling into or out of the room.

## SOUND ABSORPTION (NRC)

When sound is reflected by a surface, it loses part of its energy. This energy loss is called sound absorption or the sound absorption capability of that surface. The single number rating of how much sound an acoustic product absorbs is called the noise reduction coefficient (NRC).

The NRC is expressed as a number between 0.00 and 1.00. The higher the number, the better the surface acts as an absorber. As a guideline, an NRC of 0.7 or greater is recommended for open-plan offices.

## SOUND TRANSMISSION (STC, CAC)

When sound travels from its source through the walls, floors and ceilings of adjoining rooms, this is called sound transmission. The rating system that evaluates the effectiveness of assemblies to isolate airborne sound transmission is called the sound transmission class (STC). The ceiling attenuation class (CAC) is a related rating system specifically for sound transmission through the ceiling and plenum. A CAC of 40–44 is recommended for closed-plan offices.

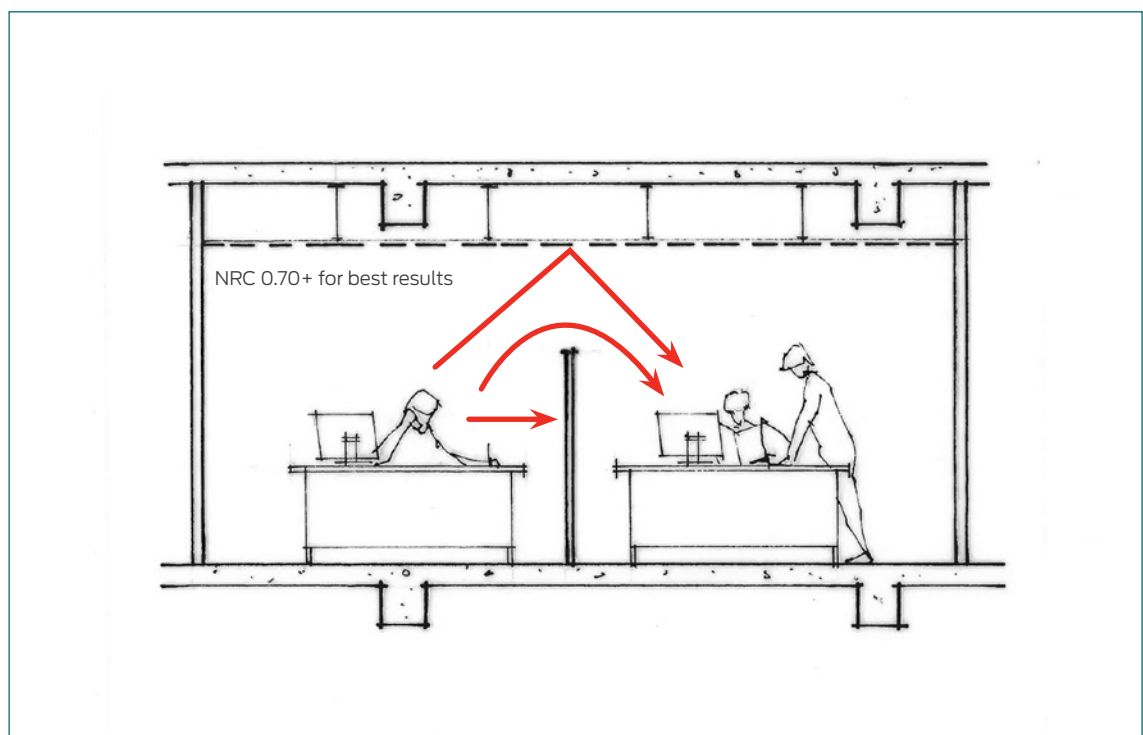

Figure 75: Sound reflection.

All materials absorb, reflect and dampen sound vibrations to some extent. Truly acoustic materials absorb sound to a measurable degree, with a minimum NRC of 0.50.

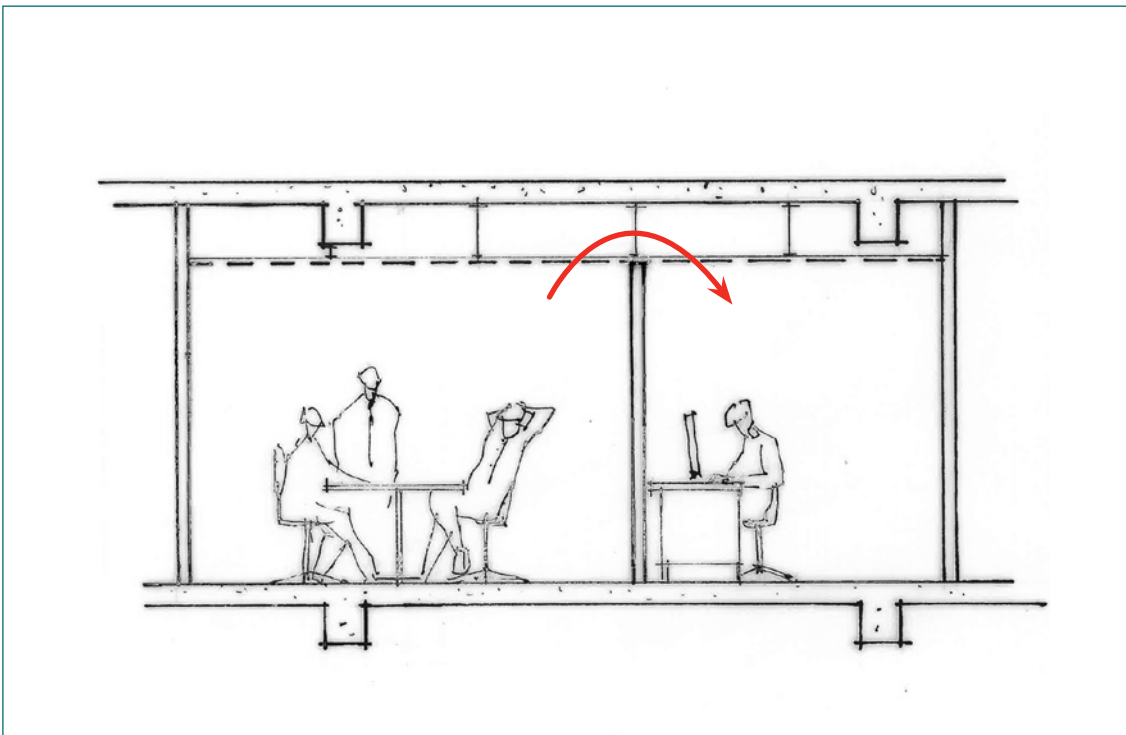

Figure 76: Sound transmission.

# 17

## Monitoring design and construction

Monitoring design and construction is a key part of the process but is often neglected. Producer statements, although not statutory documents, are commonly required by contractors. The IPENZ construction monitoring levels are also used to monitor design and construction.

### PRODUCER STATEMENTS

A producer statement<sup>9</sup> is a document prepared by a specialist confirming their professional opinion, based on stated reasonable grounds, that aspects of design of a building achieve compliance with the NZBC or that elements of construction have been completed in accordance with the approved building consent. The intent of a producer statement is evidence to the building consent authority that the design, installation and monitoring work complies.

#### Design producer statement (PS1)

A PS1 is a statement of opinion that certain aspects of proposed building work will comply with the NZBC if the work is constructed according to the referenced documentation (for example, engineering design drawings and specifications).

Where a PS1 is required for seismic design that is undertaken, a structural specialist provides structural design details and calculations and issues a PS1 certificate accordingly.

#### Design review producer statement (PS2)

A PS2 is a statement of opinion, based on a review of design documents that have been prepared by others, that the aspects of proposed building work reviewed will comply with the NZBC.

An independent engineering review by a suitably experienced Chartered Professional Engineer (CPEng) may be required:

- where the suspended ceiling subcontractor or suspended ceiling system supplier prepares designs and details for review and certification by an external structural specialist and provides a PS1, or
- where the suspended ceiling contractor prepares pre-engineered (non-project-specific) and pre-reviewed generic details from the suspended ceiling system supplier.

**Table 6: Producer statements likely to be required according to seismic grade.**

Producer statement	Seismic grade of ceiling			
	AWCI SG1	AWCI SG2	AWCI SG3	AWCI SG4
Specific engineering design and design producer statement (PS1) required?	If specified	If specified	Yes	Yes
Design review by independent structural engineer required (PS2)?	No	If specified	If specified	If specified
Construction producer statement (PS3) required?	If specified	Yes	Yes	Yes
Monitoring of installation by independent structural engineer required and issue of PS4 certification?	No	If specified	If specified	Yes

### **Construction producer statement (PS3)**

A PS3 is certification from the suspended ceiling contractor that the ceiling has been installed in accordance with the relevant design, New Zealand standards and/or building consent as applicable.

The suspended ceiling contractor should take care to ensure that the wording of the PS3 certification accurately reflects the scope of work that has been carried out.

### **Construction review producer statement (PS4)**

A PS4 is a statement of opinion, based on reasonable and stated grounds that may include the records of construction monitoring and information supplied by the contractor, that certain aspects of building work have been completed according to the building consent and amendments.

Where required by the seismic grade of the ceiling or by the tender documents, a structural specialist should provide the level of construction monitoring they consider appropriate and issue a PS4.

## **CONSTRUCTION MONITORING (CM) LEVELS**

The construction monitoring (CM) levels<sup>10</sup> and guidelines below are based on IPENZ Engineering Practice Guideline – Construction Monitoring Services.

### **Level CM2**

- Review at the earliest opportunity a sample of each important work procedure, material of construction and component for compliance with the requirements of the plans and specifications, and review a representative sample of each important completed work prior to enclosure or completion as appropriate.
- Be available to provide the constructor with technical interpretation of the plans and specification.

This is considered appropriate for building importance level 1 or 2 buildings being undertaken

by an experienced and competent suspended ceiling contractor and where a higher than normal risk of non-compliance is acceptable.

### **Level CM3**

- Review random samples of important work procedures for compliance with the requirements of the plans and specifications and review important completed work prior to enclosure or on completion as appropriate
- Be available to provide the constructor with technical interpretation of plans and specifications.

This is considered appropriate for building importance level 3 buildings being undertaken by an experienced constructor when a normal risk of non-compliance is acceptable or for building importance level 1 or 2 buildings where the suspended ceiling contractor is not experienced in seismic restraints installations.

### **Level CM4**

- Review regular samples of work procedures, materials of construction and components for compliance with the requirements of the plans and specifications and review the majority of completed work prior to the enclosure or on completion as appropriate.

This is considered appropriate for all building importance level 4 buildings where a lower than normal risk of non-compliance is required and building importance level 3 buildings where the services trade contractor is not experienced in seismic restraint installations.

<sup>8</sup> See IPENZ Practice Note 1 Guidelines on Producer Statements, January 2014 – [www.ipenz.org.nz/ipenz/forms/pdfs/PN01-Guidelines-on-Producer-Statements.pdf](http://www.ipenz.org.nz/ipenz/forms/pdfs/PN01-Guidelines-on-Producer-Statements.pdf)

<sup>9</sup> IPENZ CM1 (monitor outputs from another party's quality assurance programme) and CM5 (full-time on-site monitoring) have not been included as they are not relevant to the construction monitoring required to be carried out by a structural specialist.

# 18

## Summary of roles and responsibilities

As with any construction project, there are many parties involved. All have different roles and responsibilities, and in many steps of the process, the roles and responsibilities of several parties will overlap.

In general, the greater the collaboration and the earlier communication between all parties commences, the greater the chances of a successful project with fewer contract variations, omissions or parties ending up out of pocket.

### DESIGNER

The seismic design of suspended ceilings must be undertaken by a suitably qualified person.

The designer's responsibilities are to:

- identify the AWCI seismic grade/requirements of the ceiling
- design the ceiling
- design appropriate seismic restraints
- issue a PS1 to certify the design
- commission a PS2 if required
- issue a PS4 if contracted to do so.

The lead designer may be an architect, interior designer or engineer. The lead designer oversees the entire documentation process as a whole and must be aware of all the components in the plenum and how they interact and ensure that all parties are aware of all work by others.

Each component in the plenum may also have its own specialist designer. Ideally, the lead designer will co-ordinate all other non-structural building components in the plenum so that there are no conflicts. They may need to modify the design to co-ordinate and overcome clashes with other components and the related fixings and bracing designed by their structural specialists.

### CEILING TENDERER

The ceiling tenderer is the contractor who supplies and installs the suspended ceiling.

The tenderer's responsibilities are to:

- ensure all ceiling details 'work'
- verify the AWCI seismic grade/requirements of the ceiling (as identified by the designer or based on the information provided)
- identify a provisional sum allowance for seismic restraints (as applicable)
- review co-ordination with other trades.

### INSTALLER

The installation of suspended ceilings shall be undertaken by a suitably qualified person with experience in ceiling installation. A suitably qualified person will hold a National Certificate in Specialist Interiors (Installation) and/or be a certified tradesperson or certified business member of AWCINZ.

The installer's responsibilities are to:

- prepare shop drawings (where applicable)
- submit shop drawings (where applicable)
- obtain design approvals (if required)
- install the ceiling in accordance with the approved shop drawings or seismic design details.
- inspect seismic restraints for conformance with approved design
- issue a PS3 to certify that the installation has been completed in accordance with the design.

Before commencing any work, the installer shall visually inspect the site and raise any issues arising with the project manager. The installer shall also hold a meeting with the project manager and all other trades with components in the plenum and supported by the ceiling to co-ordinate installation scheduling, location of their components and all fixing points.

## **BUILDING CONSENT AUTHORITY**

Registered building consent authorities perform building consenting functions under the Building Act 2004.

The BCA's responsibilities are to:

- review consent documents for NZBC compliance, including the requirement for and design of seismic restraints
- review installation for conformance with consented drawings.

# Appendices

## A. DEFINITIONS, ABBREVIATIONS AND NOTATIONS

### Acceptable Solution

A prescriptive design solution comprising step-by-step instructions that, if followed, is deemed to comply with the NZBC. Acceptable Solutions and Verification Methods are published by the Ministry of Business, Innovation and Employment and often cite other documents such as New Zealand standards. Designers and builders are not obliged to use Acceptable Solutions and may put forward their own Alternative Solution proposal.

### Alternative Solution

A design solution that differs totally or partially from Acceptable Solutions or Verification Methods yet complies with the performance requirements of the NZBC. These are stand-alone solutions put forward and substantiated by the building consent applicant and considered and approved on their individual merits by a building consent authority.

### annual exceedance probability

The chance or probability of a natural hazard event (usually a rainfall or flooding event) occurring. Typically defines an earthquake that is likely to occur during the lifetime of the structure.

### AWCI seismic grade

This seismic grade allows designers to identify the extent to which a suspended ceiling must be able to resist seismic forces and/or to remain intact in the event of an earthquake.

### brace (see also K-brace, knee brace)

Component used to restrain the ceiling. Usually attached to the structure above.

### bridge

A horizontal bar supported by hangers/wires to span under ducting or services.

### building importance level

Refer Table 5.

### ceiling attenuation class (CAC) (see also STC)

Similar to STC, this rating system is specifically for sound transmission through a ceiling and plenum.

### Chartered Professional Engineer (CPEng)

A statutory title under the Chartered Professional Engineers of New Zealand Act 2002, which established a register of professional engineers whose competence is up to date.

### concealed

Term usually associated with suspension systems where the ceiling tile fully covers the suspension framing. Sometimes also used to describe a plasterboard lined ceiling.

### contract variation, site variation

An amendment to a contract that changes the original terms or conditions of the contract.

### cross tees, cross runners, cross T-bars

A cross member that interlocks with a main beam.

### designer

The person who designs the suspended ceiling.

### diffuser

A circular or rectangular metal grille used for the passage of air from a ducted system.

### earthquake action, return period

An estimate of the likelihood of an event, such as an earthquake. Also known as a recurrence interval.

### engineer

Person qualified as an engineer. May not be chartered.

**essential service buildings**

Any building designed to be used by public agencies such as a fire station, Police station, emergency operations centre or emergency communications centre.

**face load**

A force applied at right angles to a building plane.

**grid**

The main beams and cross tees of the suspension system.

**hanger wire, suspension wire**

2.5 mm annealed wire used as the primary support for the grid system.

**hanger**

A type of suspension for the ceiling. It may be wire, rod or a rigid style of brace to resist vertical movement.

**K-brace** (see also brace)

A type of brace for the ceiling. It may be wire or a rigid style of brace to resist horizontal movement in one direction.

**Knee brace** (see also brace)

A type of brace, typically used above a partition. It is normally a rigid style of brace to resist horizontal movement in one direction.

**lateral force bracing**

The bracing method used to prevent or to restrict lateral movement during a seismic event.

**linear ceiling**

Long lengths of a material, usually light metal, that form the ceiling.

**main beam, main runner, carrying tee, carrying runner, mains**

The primary suspension member supported by hanger wires.

**main contractor**

Head builder, usually appoints subcontractors for specialist building work.

**movement joint**

Area of connections designed to allow for movement.

**noise reduction coefficient (NRC)**

The amount of sound an acoustic product absorbs.

**one-way grid**

Tile edge design conceals the grid in one direction.

**perimeter clips**

Proprietary angle bracket attached directly to the wall trim, which allows for movement in the event of seismic activity and interlocks properly with the ends of a grid system.

**perimeter wires**

Hanger wires placed within 200 mm of the surrounding walls.

**plenum**

The space between the underside of the structure above and the suspended ceiling system.

**project manager**

A person who will be on site and have an overview of the whole project.

**provisional sum**

An allowance that is inserted into tender documents.

**return period**

See annual probability of exceedance.

**reverberation**

When a sound wave continues to reflect around a room after the sound at source has died out.



**seismic clip**

Proprietary clip designed to either restrain or allow for movement.

**seismic joint**

Area specified to allow for anticipated movement.

**seismic restraint**

Components used to resist seismic movement.

**seismic strut**

Vertical rigid component to resist upward movement, usually supported by diagonal braces.

**serviceability limit state (SLS)** (see also ULS)

The point where a structure can no longer be used for its intended purpose but would still be structurally sound.

**set-out point**

The specified starting point used to lay out the ceiling.

**sheeted ceiling**

Where a suspended ceiling is sheet lined and finished so that there are no air gaps to the plenum.

**slack wire**

A safety wire that is not tight or taut.

**soil type**

Ranges from hard rock to soft soil. The ground motion of an earthquake is affected by the soil profile through which the vibrations travel.

**sound absorption**

The energy lost by a sound when it strikes and is partially reflected off a surface.

**sound transmission class (STC)**

A rating system that evaluates the effectiveness of assemblies to isolate airborne sound.

**specific engineering design (SED)**

Seismic restraint design specific to a project, typically outside the scope of manufacturers' generic seismic design guides.

**splay wires**

Wires installed at an angle rather than perpendicular to the grid.

**spreader bar, spacer bar, stabiliser bar**

A bar with notches to prevent the suspension system from separating.

**strut**

A rigid style of brace to resist horizontal and vertical movement.

**suitably qualified person**

Person qualified to carry out work.

**suspension wire**

A wire rod, typically 2.5 mm diameter.

**T-rail**

An exposed grid.

**tag(s), tagged**

Design and specification changes that often have a cost implication.

**tenderer**

A person or company that puts forward an estimate of cost.

**tight turns**

Installation requirement for suspension wire.

**trapeze**

An opposing angled wire suspension system.

**two-way grid**

Grid can be seen in both directions.

**ultimate limit state (ULS)** (see also SLS)

Reached when the applied stresses exceed the strength of the structure or structural elements.

#### **Verification Method**

A prescriptive design solution comprising a calculation or test procedure, which provides an approved way of complying with the NZBC. Verification Methods (along with Acceptable Solutions) are published by the Ministry of Business, Innovation and Employment and often quote other documents such as New Zealand standards. Designers are not obliged to use the Verification Methods and may put forward their own Alternative Solution proposal.

#### **vertical struts, compression posts, seismic posts, seismic struts**

The rigid vertical member used in the bracing of the suspension system. Common materials are angles, metal studs or proprietary products.

#### **wall trim, wall moulding**

A light-gauge metal wall trim or channel fastened to the perimeter wall or partition to support the perimeter ends of an acoustical ceiling grid.

#### **wet trades**

Trades involved with installing products that give off moisture, for example, plastering.

## **B. RELEVANT STANDARDS AND ASSOCIATED DOCUMENTS**

### **Standards**

AS/NZS 1170.1:2002 *Structural design actions – Part 1: Permanent, imposed and other actions*

NZS 1170.5:2004 *Structural design actions – Part 5: Earthquake actions – New Zealand*

Provides procedures for the determination of earthquake actions on structures in New Zealand. It gives the requirements for verification procedures, site hazard determination, the evaluation of structural characteristics, structural analysis for earthquake action effects, the determination and limits for deformations and the seismic loads on parts of structures. It is to be applied in conjunction with AS/NZS 1170 parts 0, 1, 2 and 3 and relevant material standards. Appendices cover aspects of ultimate limit state design and the requirements for material-specific structural design standards that are able to be used in conjunction with NZS 1170.5:2004.

NZS 1170.5 Supplement 1: 2004 *Structural design actions – Part 5: Earthquake actions – New Zealand commentary*

Provides background to the various provisions in NZS 1170.5:2004, suggests approaches that may satisfy the intent of the standard and, if appropriate, describes differences between this and previous editions of the standard. References are provided for further reading, and these are given at the end of each section of the commentary.

AS/NZS 1530.3:1999 *Methods for fire tests on building materials, components and structures – Simultaneous determination of ignitability, flame propagation, heat release and smoke release*

AS/NZS 2785:2000 *Suspended ceilings – Design and installation*

Sets out minimum requirements for the design, construction, installation, maintenance and testing of internal and external non-trafficable suspended ceiling systems of dry construction with suspension systems attached to a supporting structure, for use in commercial, industrial and residential applications.

AS 2946-1991 *Suspended ceilings, recessed luminaires and air diffusers – Interface requirements for physical compatibility*

NZS 3404:2009 *Steel structures standard*

NZS 4219:2009 *Seismic performance of engineering systems in buildings*

NZS 4541:2013 *Automatic fire sprinkler systems*

AS/NZS 4600:2005 *Cold-formed steel structures*

Sets out minimum requirements for the design of structural members cold formed to shape from carbon or low-alloy steel sheet, strip, plate or bar not more than 25 mm in thickness and used for load-carrying purposes in buildings.

AS 1397-2011 *Continuous hot-dip metallic coated steel sheet and strip – Coatings of zinc and zinc alloyed with aluminium and magnesium*

ISO 6308:1980 *Gypsum plasterboard – Specification*

ASTM C423-09 *Test method for sound absorption and sound absorption coefficients by the reverberation room method*

ASTM E1414-11 *Standard test method for airborne sound attenuation between rooms sharing a common ceiling plenum (two-room method)*

AS ISO 354-2006 *Acoustics - Measurement of sound absorption in a reverberation room*

#### **Other documents**

Acceptable Solutions and Verification Methods for NZBC clause B1 *Structure* ([www.building.govt.nz/UserFiles/File/Publications/Building/Compliance-documents/B1-structure-1st-edition-amendment-12.pdf](http://www.building.govt.nz/UserFiles/File/Publications/Building/Compliance-documents/B1-structure-1st-edition-amendment-12.pdf))

NZBC clause B2 *Durability* ([www.building.govt.nz/UserFiles/File/Publications/Building/Compliance-documents/B2-durability-2nd-edition-amendment-8.pdf](http://www.building.govt.nz/UserFiles/File/Publications/Building/Compliance-documents/B2-durability-2nd-edition-amendment-8.pdf))

*Codewords* Issue 54 – December 2012 – Seismic resistance for engineering systems and non-structural elements ([www.building.govt.nz/codewords-issue-054#seismic](http://www.building.govt.nz/codewords-issue-054#seismic))

IPENZ Practice Note 1 *Guidelines on Producer Statements*, January 2014 ([www.ipenz.org.nz/ipenz/forms/pdfs/PN01-Guidelines-on-Producer-Statements.pdf](http://www.ipenz.org.nz/ipenz/forms/pdfs/PN01-Guidelines-on-Producer-Statements.pdf))

Generic Seismic Design Guidelines – Suspended Ceilings, 2014, USG Boral ([www.seismicceilings.co.nz/pdfs/USG%20Seismic%20Guidelines%203-14.pdf](http://www.seismicceilings.co.nz/pdfs/USG%20Seismic%20Guidelines%203-14.pdf))

## **C. TENDERING OPTIONS GUIDELINES**

AWCINZ has developed a guideline and protocol to assist in the tendering process. It lists different design methodologies that will give different outcomes. It will assist tenderers to:

- submit offers based on consistent information
- reduce the number of tags
- reduce the number of on-site variations
- reduce the number of on-site work conflicts with other trades
- give a more accurate costing
- reduce the number of variables in the tender.

It is reproduced on the following page or download at [www.awci.org.nz/suspended-ceilings/](http://www.awci.org.nz/suspended-ceilings/).

## **AWCI TENDERING PROTOCOL FOR GRID SUSPENDED CEILING INSTALLATIONS**

1. All installed suspended ceilings must comply with AS/NZS 2785:2000 and the seismic restraint requirements of AS/NZS 1170.5:2004.
2. AWCINZ members are encouraged to submit tenders for grid suspended ceilings based on this AWCI Tendering Protocol to assure compliance.
3. Options for the design of seismic restraints for Grid Suspended Ceilings include:

### **Option 1: Full design of ceiling seismic restraints system by structural engineer tender documents** ***Full seismic restraints design incorporated in building consent documentation and tender documents.***

This option is preferred to encourage fully conforming and untagged tenders, and to assure fully compliant ceiling installations.

### **Option 2: Generic Design Guides**

***New Zealand manufacturer/supplier Generic Design Guides<sup>1</sup> provide seismic bracing installation details for basic ceilings within product limitations and structural performance assumptions, for subcontractor design and pricing.***

This option encourages fully conforming tenders generally limited to Category P.7 (AS/NZS 1170.5:2005 Table 8.1) ceilings to Serviceability Limit State (SLS1) (with limited ULS options also available). Option 2 tenders should identify the proposed bracing concept, the applicable Generic Design Guide, and any underlying design assumptions\*<sup>1</sup>.

Any ceilings outside the scope of Generic Design Guides (generally being greater than 30/40 metres above ground level, or where individual components weigh more than 10 kg and are able to fall more than 3 metres onto a publicly accessible area) should be nominated in the tender and identified for specific engineering design, and a Provisional Sum allowed for engineer-designed bracing as Option 3.

- \*<sup>1</sup> Unless otherwise stated in the ceiling contractor's tender underlying assumptions include building importance level of 3 or less (AS/NZS 1170.0:2002 Table 3.2), relevant geographic location (AS/NZS 1170.5:2004 Table 3.3), annual probability of exceedance 1/25 (AS/NZS 1170.0:2002 Table 3.3), and adequate space and fixing provisions for installation of compliant seismic restraints. The main contractor or the client's structural engineer should verify tenderers' stated assumptions post-tender when full engineering data is available, and any required additional bracing should be a variation.

### **Option 3: Specific engineering design**

***Specific engineering design (required where Option 1 does not apply, and Option 2 does not apply to some or all ceilings).***

Unless full engineering data has been provided within the tender documents such design must be carried out post-tender when full structural and building performance data is available. Where the scope of seismic bracing cannot be accurately ascertained at tender a Provisional Sum\*<sup>2</sup> should be nominated for the added cost of bracing.

- \*2 A Provisional Sum (not being an estimate) for seismic bracing should identify the ceiling areas requiring specific engineering design, to cover the cost of specialist engineering design, design producer statements (PS1), supply and installation of seismic bracing, and engineer producer statements (PS4) for the actual seismic restraints. Unless otherwise stated such Provisional Sum would be additional to the tender price.

### General

- Minimum structural engineering information requirements for Options 2 and 3 include return period, building importance level, building classification, SLS/ULS, provisions for load transfer to structure, requirements for producer statement, any confirmation that services loads will be restrained in accordance with AS/NZS 4219.
- Producer statements, where specified, shall be provided for the entire design and/or the completed ceiling installation. Any additional or interim producer statements for separate areas or completion stages shall be a variation.
- Shop drawings shall comprise as a minimum reflected ceiling plans marked up to show the position and type of seismic bracing and seismic control provisions.
- Shop drawings submitted for approval shall unless approved in writing be deemed approved within 10 working days of submittal.

### Coordination of structure and services with ceiling fixings and bracing

The main contractor shall, without charge to the ceiling contractor:

- Provide suitable fixing points and all secondary steelwork, purlin blockings, etc. for fixing of ceiling hangers and bracing.
- Provide continuous nogs to allow solid fixings wherever ceilings abut partitions and bulkheads.
- Ensure that all in-ceiling services are installed strictly in accordance with AS/NZS 4219 including all components and services over 10kg are restrained from gravity and earthquake forces with proper clearances from ceiling and supports in accordance with AS/NZS 4219.
- Co-ordinate the required bracing with structure and in-ceiling services.

Any requirement for additional steelwork, to modify proposed bracing or support requirements due to a lack of structural fixings and support or for coordination with in-ceiling services would be a variation.



**Armstrong:** Armstrong Seismic Design Guide – New Zealand Version; Seismic Installations and Armstrong Ceiling Systems

**USG:** Generic Seismic Installation for USG DONN® Exposed Grid Suspended Ceilings; Seismic design Guidelines – Suspended ceilings

## D. INSTALLER'S PRODUCER STATEMENT (PS3) TEMPLATE

The PS3 below is an example of what some building consenting authorities may require from the installer.

You should attach the seismic design summary sheet(s) if you are using a manufacturer's generic design guide.

**Producer Statement (PS3)**

**Notes:**  
All sections of this form must be completed  
Forms to be completed by the installer who has carried out the work

**Author's name:** \_\_\_\_\_

**Author's company:** \_\_\_\_\_ **Building consent no.** \_\_\_\_\_

**Legal address:** \_\_\_\_\_  
\_\_\_\_\_  
\_\_\_\_\_

**Project address:** \_\_\_\_\_  
\_\_\_\_\_  
\_\_\_\_\_

**Description of all work covered by this statement:** \_\_\_\_\_  
\_\_\_\_\_  
\_\_\_\_\_

**NZBC clauses:** (usually B1 Structure but others may also apply, enter as many are applicable)  
\_\_\_\_\_  
\_\_\_\_\_  
\_\_\_\_\_

**Systems/products used (insert brand names):** \_\_\_\_\_  
\_\_\_\_\_  
\_\_\_\_\_  
\_\_\_\_\_

I have sighted the above building consent and read the attached conditions of consent. I confirm that the installed products comply with the consented plans to the extent required by the above building consent and that they comply with clauses as indicated of the Building Regulations 1992.

I understand that the Council will rely upon this producer statement for the purposes of establishing compliance with the above building consent.

**Signature:** \_\_\_\_\_ **Date:** \_\_\_\_\_

**Author's cell-phone number:** \_\_\_\_\_ **Author's office number:** \_\_\_\_\_

**Author's email:** \_\_\_\_\_

### E. SAMPLE QA SHEET

Below is a sample of a QA sheet that should be completed at the completion of every notifiable

stage of the installation contract and for every different area of project work.

## Construction Quality Control

Job number: \_\_\_\_\_

Contract name: \_\_\_\_\_ Date: \_\_\_\_\_

Main contractor: \_\_\_\_\_

Subcontractor: \_\_\_\_\_

Trade: \_\_\_\_\_

Work area/room no: \_\_\_\_\_

Work completed by: \_\_\_\_\_

Drawings ref: \_\_\_\_\_

Grid type: \_\_\_\_\_

Two way:  Screw fix:  Tile type:

	Inspection OK		Comments
	Sub foreman	Site foreman	
Grid alignment			
Grid seismic bracing			
Suspension to specification			
Bulkheads parallel and straight			
Wall channel alignment			
Service penetrations			
Service tiles issued			
Release HOLD for tile installation			
Tile installation			
Final Inspection			
Clean up work area and rubbish to bin			

**Final approvals:**

Subcontractor foreman: \_\_\_\_\_ Date: \_\_\_\_\_

Site foreman QA check: \_\_\_\_\_ Date: \_\_\_\_\_



## F. DESIGN INFORMATION LIST

Considerations when designing and installing suspended ceilings include:

- seismic design criteria and seismic design intent
- risk factors
- accelerations and movements of the primary building structure during an earthquake
- minimum clearances between hangers/plenum braces for ceilings and services
- building location
- estimated maximum number of occupants
- ceiling type and manufacturer
- weight of ceiling
- plenum depth
- weight of services
- AWCi seismic grade
- NZS 1170.5:2004 section 8 parts category
- building importance level
- annual probability of exceedance (return period)
- design working life
- ductility of parts and systems
- site hazard factor (Z)
- site subsoil class
- full set of drawings including reflected ceiling plan and services locations
- wind loads
- inter-storey drift of the structure
- ceiling height from ground and floor
- total height of building
- location of any seismic ceiling gaps
- where recessed luminaires are to be used, they shall be shown on the reflected ceiling plans
- adequate support of ceilings beneath large service ducts
- access hatches
- bulkheads
- skylights
- internal partitions.





